

ORIGINAL INSTRUCTIONS

OPERATOR'S MANUAL

STOUT



**THE
SMART
CULTIVATOR**

ENGLISH EDITION
JANUARY 2024

CONTENTS

1. GENERAL INFORMATION

Note to the Owner	4
Owner Assistance	5
Company Policy	5
Parts and Accessories	5
Lubricants	5
Warranty	5
Cleaning Your Implement	5
Disassembly or Scrapping	6
Intended Use	6
Prohibited Use	6
Electro-Magnetic Compatibility	7
Normal Operation	8
Routine Service & Maintenance	8
Periodic Service, Conversions and Repairs	8
Before You Operate	9
Additional Documents	9
Product Identification Number	10
Product Identification	11
Operator's Manual Storage on the Machine	12
Implement Orientation	12
Implement Components	13
Module Assembly	14

2. SAFETY INFORMATION

Safety rules and signal word definitions	15
General Recommendations	15
Illustrations	16
Local Obligations	16
Fire or Explosion Prevention	16
Hazardous Chemicals	16
Starting Up the Implement Safely	17
Traveling on Public Roads	17
Passengers	17
Transport Safety	18
Drive Safe	18
Operating the Implement Safely	18
Maintenance	19
Personal Protective Equipment (PPE)	20
Safety Requirements for Fluid Power Systems and Components	21
Noise Emission	21
Implement Stability	22
Ecology and the Environment	23
Safety Signs	24
Safety Location	25

3. CONTROL & INSTRUMENTS

Monitor	29
Touch Screen Tabs	29
Set Up Tab	30
Alarms Tab	30
Configuration Tab	31
Service Tab	31
Fault Tables	32

4. OPERATING INSTRUCTIONS

Connection to the Tractor	35
Start Up Procedure	37
Shut Down Procedure	37
Configuration How To: Spacing Out Gauge Wheel for Different Sized Beds	38
Configuration How To: 6 Line to 5 Line Set Up	44
Configuration How To: 6 Line to 4 Line 40's Set Up	55

5. TRANSPORT OPERATIONS

Transport on Public Roads	60
Shipping Transport Lifting the Implement	61
Loading and Unloading of the Implement with Suitable Lifting Device	62

6. MAINTENANCE

Tire Pressure Settings	63
Fluids, Lubricants and Capacities	63
Recommended Tools	63
High Pressure Filter Maintenance	64
Height Control Wheel Maintenance	65
Pressure Settings	66

7. TROUBLESHOOTING

Problem: The Hydraulic System is Not Operating	75
--	----

8. SPECIFICATIONS

Technical Data	76
Wheels	77

9. FORMS AND DECLARATIONS

European Community (EC) Declaration of Conformity	78
---	----

STOUT

A red lightning bolt graphic is positioned below the word "STOUT", extending from the bottom of the 'S' to the bottom of the 'T'. The bolt is stylized with a jagged, zig-zag shape.

1. GENERAL INFORMATION

Note to the Owner

This manual has been prepared to assist you in the correct procedure to run in, to drive, to operate, to adjust and to maintain your new implement.

This implement has been designed and built to give maximum performance, economy and ease of operation under a wide variety of conditions.

Prior to delivery, your implement was carefully inspected both at the factory and by your dealer to make sure that it reaches you in optimum condition. To maintain this condition and assure trouble-free operation it is important that routine services, as specified in this manual, are carried out at the recommended intervals.

Read this manual carefully (especially section 2 that covers the safety information) and keep this manual in a convenient place for future reference. **DO NOT** operate or permit anyone to operate or service this implement until you and/or other persons have read this manual. Read the manual, it will save you time and hassle later. Lack of knowledge can lead to accidents. Employ only trained operators who have demonstrated the ability to operate and service this implement correctly and safely. Contact your dealer for assistance providing the required training to your operators. Contact your dealer to obtain additional manuals or alternate language versions.

If at any time you require advice that concerns your implement, do not hesitate to contact your authorized dealer. Your dealer has factory-trained personnel, genuine service parts and the necessary equipment to carry out your service requirements.

NOTICE: This implement has been designed and built in line with the requirements put forward by the European Directives 2006/42/EC and 20 14/30/EU.

Always use genuine STOUT Service Parts or parts that match at least the same quality, reliability and functionality as the equivalent original Service Parts when you service and repair your implement and do not modify your implement without a written permission of the manufacturer. Failure to do so will void the responsibility of the manufacturer.

Check local road legislation before you drive the implement on public roads.

As this publication is distributed throughout our international network, the implement illustrated, either as standard or as an accessory, may vary according to the

country in which the implement is to be used. Low specification configurations, as chosen by the customer, may deviate from the specifications herein.

Several figures in this operator's manual show the safety guarding or the additional guards, legally required by certain countries, open or removed to better illustrate a particular feature or adjustment. The implement must not be used in this condition. For your own safety, make sure that all guards are closed or replaced before you operate the implement.

1. GENERAL INFORMATION

OWNER ASSISTANCE

We at STOUT and your dealer want you to be completely satisfied with your investment. Normally, your dealer's Service Department will handle any problems with your implement. Sometimes however, misunderstandings can occur. If your problem has not been handled to your satisfaction, we suggest you to contact the owner or General Manager of the dealership, explain the problem and request assistance. When additional assistance is needed, your dealer has direct access to our branch office.

COMPANY POLICY

Company policy, which is one of continuous improvement, reserves the right to make changes in design and specification at any time without notice and without obligation to modify units previously built.

All data given in this book is subject to production variations. The information in this publication is provided on the basis of information that was available at the time that the manual was written. Settings, procedures and other items can change. These changes can affect the service that is given to the implement. Dimensions and weights are approximate only and the illustrations do not necessarily show the implement in standard condition. For exact information about any particular implement please consult your dealer. Make sure that you have the most current and complete information from your dealer before you start any job.

PARTS AND ACCESSORIES

Genuine STOUT parts and accessories have been specifically designed for STOUT implements.

We would like to point out that "non-genuine" parts and accessories have not been examined and released by STOUT. The installation and/or use of such products could have negative effects upon the design characteristics of your implement and thereby affect its safety. STOUT is not liable for any damage caused by the use of "non-genuine" parts and accessories.

Rely on your authorized dealer to supply you with genuine STOUT parts only. These parts are covered by our warranty and will give you the best performance. Contact your dealer to find genuine service parts for your implement.

When you order service parts, always quote the model and serial number printed on the Product Identification Number (PIN) plate.

LUBRICANTS

Your dealer sells a selection of specially formulated lubricants based on STOUT engineering specifications. Recommended lubricants for your implement are listed in the maintenance section.

WARRANTY

Your implement is warranted according to legal rights in your country and the contractual agreement with the selling dealer. No warranty shall, however, apply if the implement has not been used, adjusted and maintained according to the instructions given in this operator's manual.

It is prohibited to carry out any modifications to the implement unless specifically authorized, in writing, by a STOUT representative.

CLEANING YOUR IMPLEMENT

When you use a high pressure washer, do not stand too close to the implement and avoid directing the jet at electronic components, electrical connections, breathers, seals, filler caps, and so on.

Clean decals only with a soft cloth, water and a gentle detergent. DO NOT use solvent, gasoline or other harsh chemicals to clean decals. Decals could be removed or get damaged.

1. GENERAL INFORMATION

DISASSEMBLY OR SCRAPPING

When the costs of repair, restoration or replacement of the individual components and/or assemblies become economically impractical.

When your implement is taken out of service because it is damaged beyond repair or has reached the end of its useful life, disassembly, scrapping and/or recycling of components must be performed only by a qualified technician with service instructions, and in compliance with local law and regulations.

INTENDED USE

The implement was developed for agricultural work. Connect the implement only to agricultural tractors with the correct specifications and only drive it by hydraulic and electrical system on the agricultural tractor.

This is a software-defined, tractor drawn implement that uses machine vision and artificial intelligence to cultivate and weed fields using mechanical blades.

The implement equipped with Stout True Vision® technology, is designed to have the ability to operate on a wide range of crops. For more information regarding supported crops, visit www.stout.ai.

Each implement clears 1-2 acres per hour depending on soil conditions using mechanical blades controlled by our proprietary AI model that recognizes each weed and each plant individually.

The machines are purpose-built to work in the field, day and night. The work must occur under reasonable conditions, with normal cultivation without foreign matter and the like. The performance of the implement will depend on the crop, the condition of the field, the ground, and finally the weather.

Intended use implies that you observe the prescriptions concerning adjustment, operation and maintenance in the instruction manual. Observed altogether the safety instructions as well as common rules concerning technical safety, working practices and road safety.

If you notice degradation of performance, contact your dealer for assistance. They may have useful information for improvements, or a kit may be available to enhance the performance.

In accordance with routine maintenance and normal operating conditions, the assigned service life for the implement is minimum seven years.

PROHIBITED USAGE

NOTICE: DO NOT use this implement for another purpose than intended by the manufacturer (as described in the manual, shown by the decals, or in other product safety information provided with the implement). These information sources define the intended use of the implement.

Any other use beyond the intended use is regarded as misuse. The manufacturer is not responsible for any damage that results from the improper use of the implement. The user bears that risk.

Contact your local dealer when you are not sure about the use or function of your implement in a particular application (for example crop, variety, unique conditions, etc.), or you do not know if there is a need for special equipment or special precautions.

No parts should be fitted to this implement, which have not been released by STOUT. They might affect the implement operation, safety of the user or other people, stability or wear characteristics of the implement. They may also void the homologation approval obtained for your country and compliance with EC directives.

Do not make changes to the implement and its construction without the permission from the manufacturer. The manufacturer does not accept any responsibility for damages that results from unauthorized modification.

1. GENERAL INFORMATION

ELECTRO-MAGNETIC COMPATIBILITY

This machine complies strictly with the European Regulations on electro-magnetic emissions. However, interference may arise as a result of add-on equipment which may not necessarily meet the required standards. As such interference can result in serious malfunction of the unit and/or create unsafe situations, you must observe the following:

- Ensure that each piece of non-STOUT equipment fitted to the machine bears the CE mark.
- The maximum power of emission equipment (radio, telephones, etc.) must not exceed the limits imposed by the national authorities of the country where you use the machine.
- The electro-magnetic field generated by the add-on system should not exceed 24 V/m at any time and at any location in the proximity of electronic components.

Failure to comply with these rules will render the STOUT warranty null and void.

1. GENERAL INFORMATION

MANUAL SCOPE AND REQUIRED TRAINING LEVEL

INTRODUCTION TO THIS MANUAL

This manual gives information about the use of your STOUT machine as intended and under the conditions foreseen by STOUT during normal operation, routine service, and maintenance.

This manual does not contain all the information that relates to periodic service, conversions, and repairs that only trained service personnel can perform. Some of these activities may require appropriate facilities, technical skills, and/or tools that STOUT does not supply with the machine.

The manual contains the chapters as shown on the Contents pages. See the Index at the end of this manual to locate specific items about your STOUT machine.

NORMAL OPERATION

Normal operation consists of the use of this machine for the purpose STOUT intends by an operator that:

- Is familiar with the machine and any mounted equipment or towed equipment
 - Complies with the information on operation and safe practices as specified by STOUT in this manual and by the signs on the machine.
- Normal operation includes:
- Preparation and storage of the machine
 - Addition and removal of ballast
 - Connection and disconnection of mounted equipment and/or towed equipment
 - Adjustment and configuration of the machine and equipment for the specific conditions of the job site, field, and/or crop
 - Movement of components into and out of working positions

ROUTINE SERVICE & MAINTENANCE

Routine service and maintenance consists of the daily activities necessary to maintain the proper machine function.

The operator must:

- Be familiar with the machine characteristics
- Comply with the information on routine service and safe practices as specified by STOUT in this manual and by the signs on the machine.

Routine service can include:

- Fueling
- Cleaning
- Washing
- Topping up fluid levels
- Greasing
- Replacing consumable items such as light bulbs

PERIODIC SERVICE, CONVERSIONS, AND REPAIRS

Periodic service consists of activities that are necessary to maintain the expected life of the STOUT machine. These activities have defined intervals.

Trained service personnel familiar with the machine characteristics must perform these activities at the defined intervals. Trained service personnel must comply with the information on periodic service and safe practices as partly specified by STOUT in this manual and/or other company literature.

Periodic service includes:

- Oil change service for the engine, hydraulic circuits, or transmission
- Periodic exchange of other substances or components as required

Conversion activities rebuild the STOUT machine in a configuration that is appropriate for a specific job site, crop, and/or soil conditions (e.g., installation of dual wheels). Conversion activities must be done:

- By trained service personnel familiar with the machine characteristics
- By trained service personnel that comply with the information on conversion as partly specified by STOUT in this manual, assembly instructions, and/or other company literature.

Repair activities restore proper function to a STOUT machine after a failure or degradation of performance. Dismantling activities occur during the scrapping and/or dismantling of the machine.

1. GENERAL INFORMATION

Trained service personnel familiar with the machine characteristics must perform these activities. Trained service personnel must comply with the information for repair as specified by STOUT in the service manual.

BEFORE YOU OPERATE

Read this manual before you start the engine or operate this STOUT machine. Contact your dealer if:

- You do not understand any information in this manual
- You need more information
- You need assistance

All persons training to operate, or who will operate this STOUT machine should be old enough to possess a valid local vehicle operating permit (or meet other applicable local age requirements). These persons must demonstrate the ability to operate and service the STOUT machine in a correct and safe manner.

ADDITIONAL DOCUMENTS

When required, the machine is delivered with an assembly instruction. The assembly instruction shows the packaging depending on the kind of shipment and the related procedure to assemble the received components.

1. GENERAL INFORMATION

PRODUCT IDENTIFICATION NUMBER

The Product Identification Number (PIN) is a serial number that identifies the implement.

The serial number, model and other specifications are on the PIN plate.

Provide your dealer with the model and the PIN when you order parts.

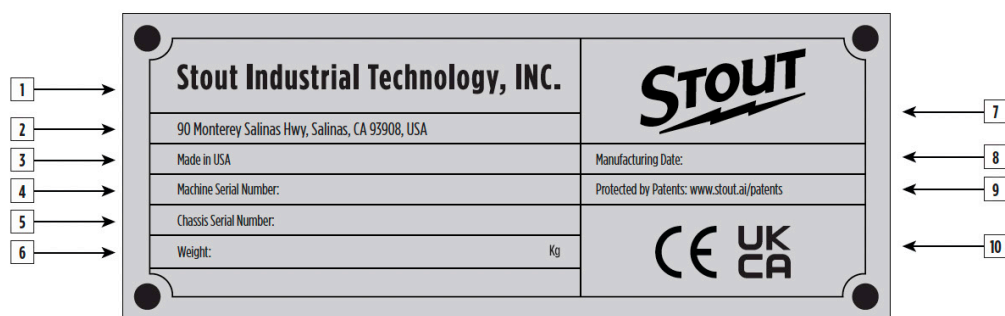

- | | |
|--------------------------|-------------------------|
| 1. Company Name | 6. Weight |
| 2. Mailing Address | 7. Logo |
| 3. Country of Origin | 8. Manufacturing Date |
| 4. Machine Serial Number | 9. Protected by Patents |
| 5. Chassis Serial Number | 10. Certification Marks |

1. GENERAL INFORMATION

PRODUCT IDENTIFICATION

NOTE: Do not remove or change the product identification Number (PIN) Plate (1) on the implement.

The PIN plate (1) is located on the location shown below.

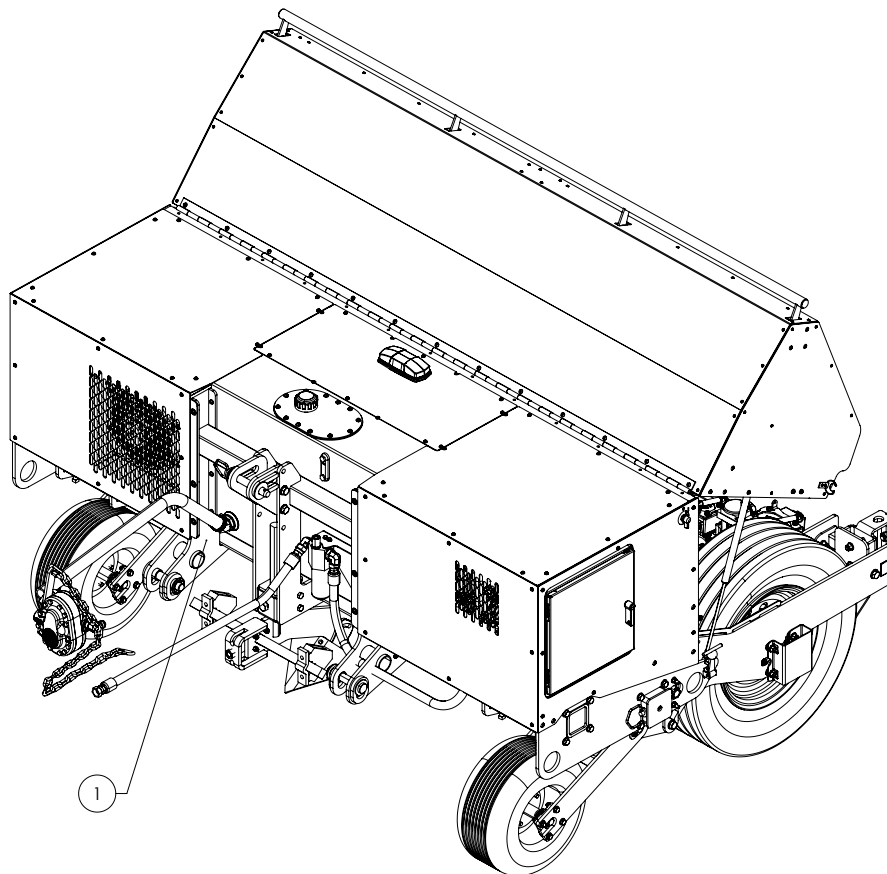

For future reference, record your implement model and pin in the spaces below.

Model:

Product Identification Number (PIN):

1. GENERAL INFORMATION

OPERATOR'S MANUAL STORAGE ON THE MACHINE

Keep this operator's manual protected and accessible on the tractor whenever you transport or operate the implement.

IMPLEMENT ORIENTATION

NOTE: To determine the left-hand side and the right-hand side of the implement, stand behind the implement and face the direction of travel during working operation.

The following overhead view illustration is a general representation of the implement. The illustration indicates the sides, front, and rear orientations of the implement as referred to throughout this operator's manual.

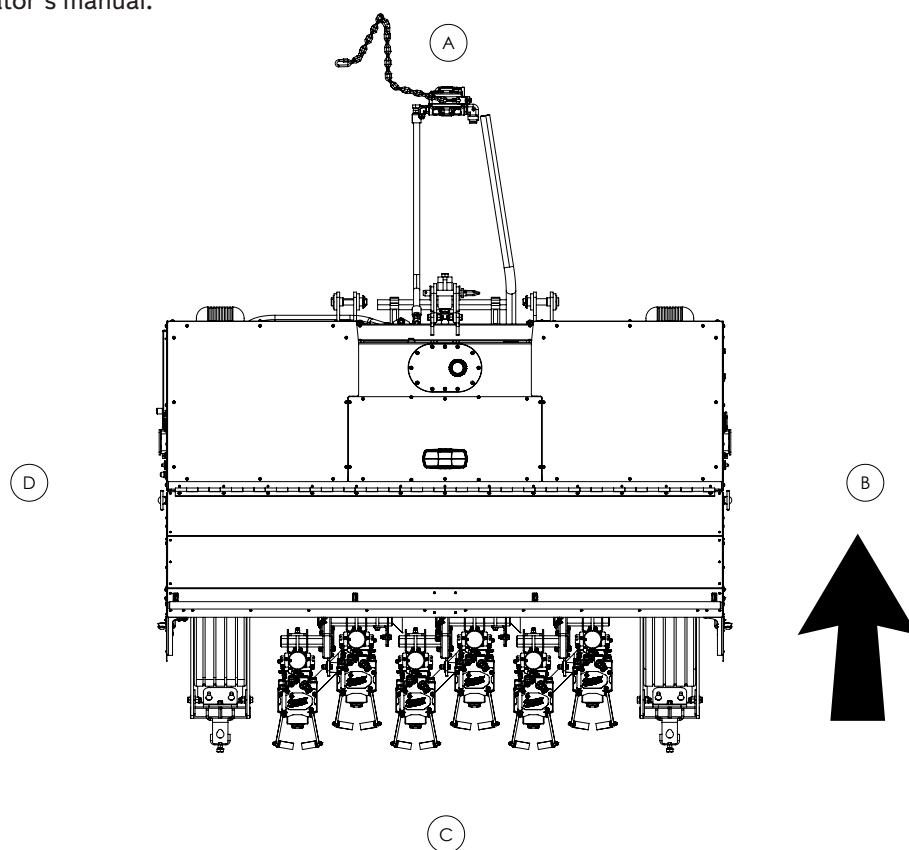

NOTE: The arrow indicates the direction of the implement during working operation.

- (A) Front of the implement
- (B) Right-hand side of the implement
- (C) Rear of the implement
- (D) Left-hand side of the implement

1. GENERAL INFORMATION

IMPLEMENT COMPONENTS

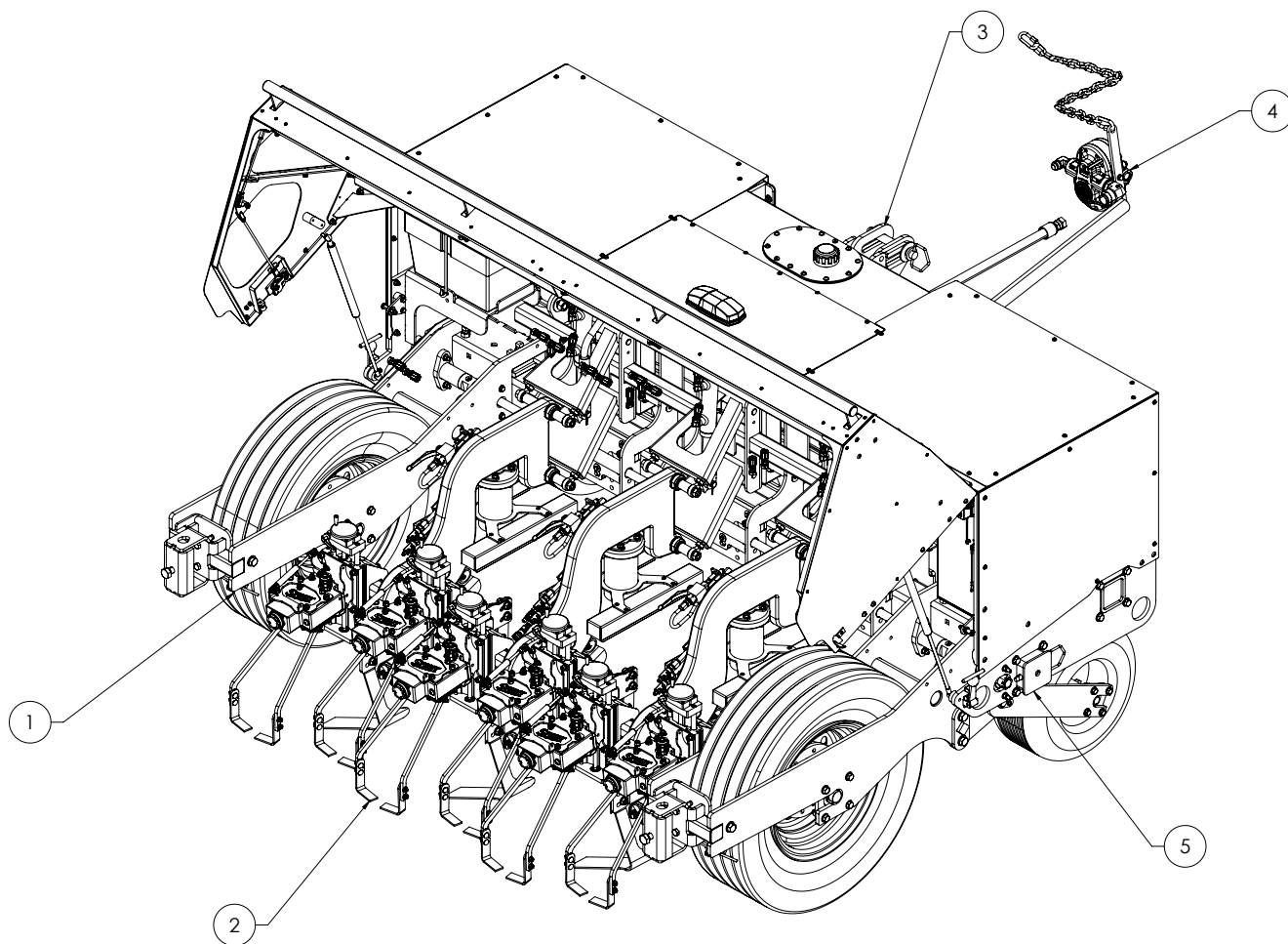

Standard equipment:

- (1) Furrow wheels
- (2) Working section
- (3) 3-Point hitch
- (4) Power Take-Off (PTO) pump
- (5) Safety support legs

1. GENERAL INFORMATION

MODULE ASSEMBLY

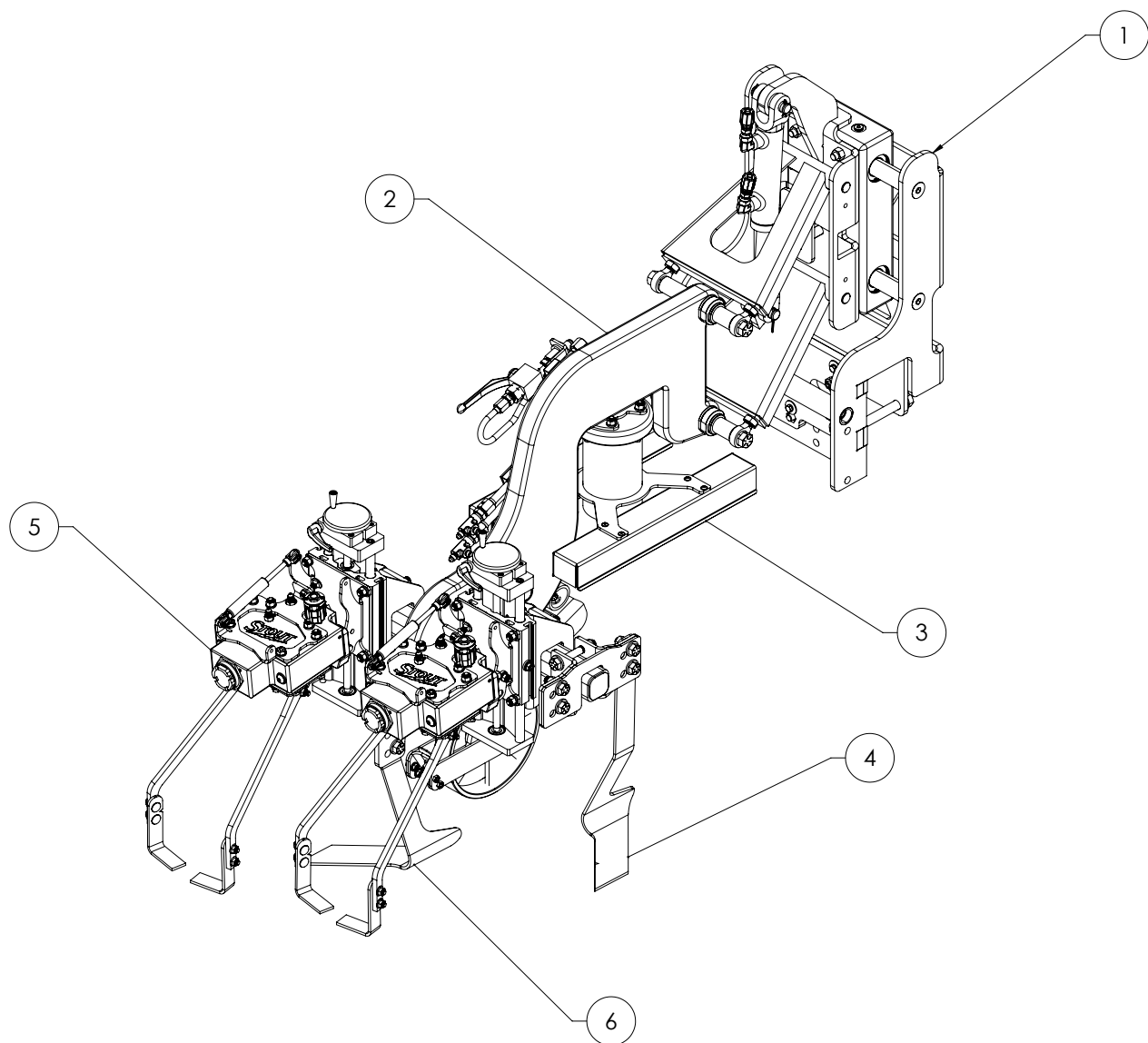

- Working section:
- (1) Module side-shift bracket
 - (2) Backbone
 - (3) Module vision package
 - (4) Long sweep assembly
 - (5) Actuators
 - (6) Short sweep

2. SAFETY INFORMATION

SAFETY RULES AND SIGNAL WORD DEFINITIONS

Personal Safety

This is the safety alert symbol. It is used to alert you to potential personal injury hazards. Obey all safety messages that follow this symbol to avoid possible death or injury.



Throughout this manual you will find the signal words **DANGER**, **WARNING**, and **CAUTION** followed by special instructions. These precautions are intended for the personal safety of you and those working with you.

Read and understand all the safety messages in this manual before you operate or service the machine.

DANGER indicates a hazardous situation that, if not avoided, will result in death or serious injury.

WARNING indicates a hazardous situation that, if not avoided, could result in death or serious injury.

CAUTION indicates a hazardous situation that, if not avoided, could result in minor or moderate injury.

FAILURE TO FOLLOW DANGER, WARNING, AND CAUTION MESSAGES COULD RESULT IN DEATH OR SERIOUS INJURY.

Machine Safety

NOTICE: Notice indicates a situation that, if not avoided, could result in machine or property damage.

Throughout this manual you will find the signal word Notice followed by special instructions to prevent machine or property damage. The word Notice is used to address practices not related to personal safety.

Information

NOTE: Note indicates additional information that clarifies steps, procedures, or other information in this manual.

Throughout this manual you will find the word Note followed by additional information about a step, procedure, or other information in the manual. The word Note is not intended to address personal safety or property damage.

GENERAL RECOMMENDATIONS

Most farm machinery accidents can be avoided by the observance of a few simple safety precautions.

- This operator's manual contains important information concerning operation, maintenance and adjustment of the implement. Furthermore, this operator's manual mentions and emphasizes all the safety instructions.
- Read the operator's manual thoroughly before you start, operate, service, or carry out any other operation on the implement. Even though you have been using a similar implement before, you must read the manual. This is a matter of your own and other people's safety. A few minutes reading will save you time and hassle later. Lack of knowledge can lead to accidents.
- In case of an accident, stop the tractor, turn off the engine and remove the key from the contact, assess the situation and call emergency services when required.
- Your implement was designed with safety in mind. However, there is no real substitute for caution and attention when you need to prevent an accident. Once an accident has occurred, it is too late to think about what you should have done. This means that it is very important that you as user of the implement pay attention and use the implement correctly and thereby avoid exposing yourself and others to unnecessary danger.
- The implement must be operated only by responsible persons who have been adequately trained and authorized to use the implement. Never leave the implement to others before you have made sure that they have the necessary knowledge to operate the implement safely.
- Never let the implement run without supervision.
- Always keep a first aid kit handy.
- The implement has only one operator station and this is the cab of the tractor. Never permit anyone to ride on or in an implement. Do not allow riders on the implement or tractor; do not allow people to stand on the ladder or steps. Your view to the left or right will be obstructed and a rider risks to fall from the implement or tractor during unforeseen or abrupt movements. There is no need for other people on or around the implement during normal operation.

2. SAFETY INFORMATION

- Do not use this implement as a lift, ladder or platform to work at heights.
- Before you work on the implement, disengage all drives, stop the engine and remove the ignition key. Wait for the rotating parts to run down.
- Never work around the implement with loose clothing, jewelry, watches, long hair and other loose or hanging items can be pulled in by the moving parts of the implement.

ILLUSTRATIONS

Illustrations in this manual may show protective shielding open or removed to better illustrate a particular feature or adjustment.

Replace all shields before operating the machine.

Failure to comply could result in death or serious injury.

NOTE: Some of the illustrations in this manual have been obtained by photographing prototypes. Standard production machines may differ in some details.

LOCAL OBLIGATIONS

Your machine may be equipped with special guarding or other devices in compliance with local legislation. Some of these require active action by the operator. Therefore, check local legislation on the usage of this machine.

FIRE OR EXPLOSION PREVENTION

1. Crop material, trash, debris, bird nests or flammable material can ignite on hot surfaces.
2. Inspect the electrical system for loose connections or frayed insulation. Repair or replace loose or damaged parts.
3. Do not store oily rags or other flammable material on the implement.
4. Do not weld or flame cut any items that contain flammable material. Clean items thoroughly with non-flammable solvent before you weld or cut with a flame.

5. Do not expose the implement to flames, burning brush or explosives.
6. Promptly investigate any unusual smells or odors that may occur during the operation of the implement.

HAZARDOUS CHEMICALS

1. If you are exposed to or come in contact with hazardous chemicals you can be seriously injured. The fluids, lubricants, paints, adhesives, coolant, etc. required for the function of your machine can be hazardous. They may be attractive and harmful to domestic animals as well as humans.

2. Material Safety Data Sheets (MSDS) provide information about the chemical substances within a product, safe handling and storage procedures, first aid measures and procedures to be taken in the event of a spill or accidental release. MSDS are available from your dealer.

3. Before you service your machine check the MSDS for each lubricant, fluid, etc. used in this machine. This information indicates the associated risks and will help you service the machine safely. Follow the information in the MSDS, on manufacturer containers, as well as the information in this manual when you service the machine.

4. Dispose of all fluids, filters and containers in an environmentally safe manner in accordance with local laws and regulations. Check with local environmental and recycling centers or your dealer for correct disposal information.

5. Store fluids and filters in accordance with local laws and regulations. Use only appropriate containers for the storage of chemicals or petrochemical substances.

6. Keep fluids and filters out of reach of children or other unauthorized persons.

7. Additional precautions are required for applied chemicals. Obtain complete information from the manufacturer or distributor of the chemicals before you use them.

2. SAFETY INFORMATION

STARTING UP THE IMPLEMENT SAFELY

Before you attach the implement to the tractor, ensure that the tractor is in good working order and that the brakes are effective, particularly if you operate on hilly ground. Also, ensure that the hydraulic or pneumatic system is compatible with that of the implement.

When you attach the implement to the tractor:

- Never allow anyone to stand between the tractor and the implement. An unintentional maneuver with the tractor may cause serious injury.
- Never go under an unsupported implement.
- Before you start the implement, learn all components of the implement and service equipment.
- Before you start the implement, make sure that all sub-assemblies are fully operational and complete. Pay particular attention to all locks and safety devices.
- Before you start the implement, repair or replace all malfunctioning elements with new ones.
- Never start the tractor until all persons are safely away from the tractor and the implement.
- Make sure that all tools have been removed from the implement before starting the tractor.
- Make sure that all spare part and moving equipment are intact and have been mounted correctly.
- Do not stand near the implement while it is working.

TRAVELING ON PUBLIC ROADS

WARNING

Loss of control hazard! Uneven brake force exists on left-handed and right-handed brakes. Always use brake pedal coupler when traveling on public roads to ensure brakes are actuated together. Failure to comply could result in death or serious injury.

WARNING

Impact hazard! Take care when making turns. The machine rear end swings out when changing direction. Failure to comply could result in death or serious injury.

The implement is built according to the homologation requirements of your country. Do not modify the implement in a way that would conflict with the national regulations.

If you wish to transport the implement on the public road, make sure that the combination tractor and implement observes the traffic rules in your country. This gives you and your surroundings the best possible safety.

The operators must observe relevant statutory or other national regulations that deal with road safety and labor safety issues.

Before you drive the implement on public roads:

- Check the allowable transport dimensions and weights.
- Correctly install the lighting and the warning panels.

Always observe the principles for permissible axle loads, the total unit mass and the transport gauge.

Observe the tractor manufacturer regulations and recommendations, specifically those relating to maximum transport loads and maximum speed.

Even in similar circumstances, the maximum allowed speed can vary depending on which country you travel in.

Always drive with the statutory lights and safety marking during transport on public road and at night.

Install all the required signs that indicate the vehicle width. Also install all the required lights that indicate the vehicle width during the nightly transport. If in doubt, contact your government department responsible for road transport.

Travel may be restricted to certain road types.

Transport may be restricted to daytime or outside peak traffic hours. However plan your route to avoid heavy traffic and peak traffic hours.

PASSENGERS

Do not allow passengers to ride in the tractor unless a specific seat is provided.

During transport, the transportation of people on the top of the implement is strictly forbidden.

2. SAFETY INFORMATION

TRANSPORT SAFETY

Transport the implement only in transport position. Secure the implement for transport. Always activate the mechanical transport safety devices before transport.

Make sure to fit all the hitch pins with retaining pins correctly. Mechanically secure the hydraulic cylinders to prevent cylinders from creeping.

DRIVE SAFE

Do not drive under the influence of alcohol or drugs.

Travel slowly in crowded areas.

When you maneuver the tractor with the implement, always be aware and conscious of its size.

The tractor driver must not leave the cabin during transport.

Always consider other road users.

Always adopt safe driving practices. Slow down and signal before turning. Give way to oncoming traffic in all situations, including narrow bridges, intersections etc.. Pull over to allow faster traffic to pass.

If the implement is marked with a maximum speed limit, never exceed this maximum speed limit.

Always adjust the driving speed to the road and weather conditions. In case of bad road conditions and high driving speeds, big forces may occur and cause overload of tractor and implement.

Drive at a safe speed to ensure control and ability to stop in an emergency.

Lock the tractor brake pedals together. Never use independent breaking at transport speeds.

Mounted implements and ballast weights influence the driving, steering and braking capacity of the tractor. Make sure that the additional weight of the implement on the linkage does not compromise driving, steering and braking capacity of the tractor. Install front weights or repair the brakes if the tractor is not safe to drive.

Reduce speed during turns. Tractors have not been designed for fast turning. Avoid that the rear end of the implement hits an obstacle.

When you turn during transport pay attention to the overhang and/or oscillating weight of the implement. Use engine braking when you drive down hills. Do not coast.

Watch for obstructions, particularly if over-width. Observe any load ratings applicable on bridges.

After you finish the transport, before you leave the tractor, always lower the implement to the ground in parking position, turn off the tractor engine, pull the parking brake, and remove the key from the ignition.

OPERATING THE IMPLEMENT SAFELY

WARNING

Roll-over hazard! Special care is required when operating the machine on slopes or in a tilted position. A wrong maneuver or unexpected event could create a dangerous situation.

WARNING

Hazard to bystanders! Always sound the horn before starting the machine. Make sure the work area is clear of other persons, domestic animals, tools, etc., before you operate the machine. Never allow anyone in the work area during machine operations. Failure to comply could result in death or serious injury.

NOTE: Only put the implement into operation according to the manufacturer's instructions.

Never operate the implement under the influence of alcohol, drugs, or while otherwise impaired.

Before you operate the implement, familiarize yourself with all facilities and operating elements. Once an accident happens it is too late to think about what you did.

Examine the work surface for hidden obstacles. Obstacles pose a risk.

Keep people away from the implement during operation. Ask bystanders to leave the field. There is the risk for bystanders to be overrun by the implement. Stop the implement immediately if someone approaches.

The tractor or its implement may strike or crush against a person or pet within the operator area of the tractor. Do not allow anyone to enter the work area. Make sure that the area is clear and operation is safe before you move the implement.

2. SAFETY INFORMATION

Before you raise or lower the implement, check that nobody is near the implement or touches the implement.

When you operate the implement, always remain seated in the tractor cab. Operate controls only when seated in the tractor seat, except for those controls expressly intended for use from other locations.

The transportation of people on top of the implement is strictly forbidden at all times.

Avoid using the implement in unsuitable weather conditions. It is better to stop work temporarily rather than to operate in such conditions.

Do not operate the implement during a thunderstorm. If you are on the ground during a thunderstorm, stay away from machinery and equipment. Seek shelter in a permanent, protected structure.

If a lightning from a thunderstorm should strike during operation, remain in the tractor cab. Do not leave the cab. Do not make contact with the ground or objects outside the machine.

Always operate the implement at a safe speed in accordance with the ground conditions. On uneven ground, proceed with the utmost caution to ensure proper stability.

When you turn on hillsides always be careful. Adjust the speed to these conditions.

Drive in a low tractor gear if you work on hillsides. When you drive up and down and across hillsides, avoid sharp turns.

When you turn during operation, pay attention to the overhang and/or oscillating weight of the implement. Avoid changing direction abruptly, avoid dangerous pitching of the implement.

Pay the necessary attention while you operate next to public roads or footpaths.

Danger of death by electrocution! Pay special attention to the overhead power lines. Always ask the owner of the field about the presence of overhead power lines. Make sure the implement has sufficient clearance to pass in all directions (also with raised or opened implement components). Consider the radio aerial(s) or any other accessory or parts which may have been added afterwards.

High voltage lines may require significant clearance for safety. Contact local authorities or utilities to obtain safe clearance distances from high voltage power lines. Should a contact between the implement and an electric power line occur, then the following precautions must be taken: Stop the implement movement immediately, stop the tractor engine and apply the tractor handbrake.

Check if you can safely leave the cab or your actual position without direct contact with electric wires. If not, stay in your position and call for help. If you can leave your position without touching the lines, jump off the last step or support position and make sure that there is no contact between any part of your body, the tractor and the ground at the same time. Never touch the tractor or the implement afterwards until power to the lines has been shut off. When people approach the tractor or the implement, warn them not to touch the tractor or the implement but to ask the electric power supply company to shut off the power to the lines.

MAINTENANCE

WARNING

Maintenance hazard! Before you start servicing the machine, attach a DO NOT OPERATE warning tag to the machine in a visible area. Failure to comply could result in death or serious injury.

- Follow the maintenance schedule with regard to the implement servicing intervals.

Remember that the implement requires attention from time to time. Also remember that the maintenance will greatly extend the life of the implement.

- Take the necessary precautions: not to spill any oil, fuel or grease.

To avoid oil and grease contact with your skin, wear protective gloves.

- Service the implement on a firm level surface.

- Do not attempt to remove material from any part of the implement, clean, lubricate or carry out any adjustments on the implement while it is in use.

- Keep hands, feet and/or garments away from parts which move.

2. SAFETY INFORMATION

- Raised implement and/or loads can fall unexpectedly and crush persons underneath. Never enter or allow anyone to enter the area underneath raised implement during operation.

Unsupported hydraulic cylinders can lose pressure and drop the implement and cause a crushing hazard. Do not leave the implement in a raised position while parked or during service, unless securely blocked on wooden blocks.

- Never work under a raised implement unless a support chain or other mechanical securing device secure the link arms of the tractor so that the implement cannot move to a lower position unintentionally.

- Relieve the pressure, stop the engine and remove the ignition key, before you connect or disconnect fluid lines.

- Before you adjust, clean, lubricate or you carry out repairs on the implement, stop the engine and remove the ignition key.

- Any leakage of hydraulic oil or fuel under pressure may cause severe harm, so always use a shield, goggles and gloves when you trace oil or fuel leaks.

Do not use your hand to check for leaks. Use a piece of cardboard or paper.

- Continuous long term contact with hydraulic fluid may cause skin cancer. Avoid long term contact and wash the skin promptly with soap and water.

- If hydraulic fluid or diesel penetrates the skin, seek medical care immediately.

- Observe all recommendations that are mentioned in this manual such as service intervals, torques, lubricants, etc..

- Always replace all parts that have damage or wear.

- Never build flexible hose assemblies from hoses that were previously part of a hose assembly.

- Never weld to the tubes.

- Always use gloves when you work with parts on the implement as the parts can have sharp edges.

- Transmission and hydraulic lines may become hot during operation. Be careful when you service such components. Allow surfaces to cool before you handle

or disconnect hot components. Wear protective equipment when required.

- Make sure that tires are correctly inflated. Do not exceed any recommended load or pressure. Over pressure could cause explosion hazard, with risk of death or serious injury. Follow the instructions in the manual for proper tire inflation

- Tires are heavy. Always handle the tires with proper equipment. Failure to comply could cause death or serious injury.

- Never weld on a wheel with a tire installed. Always remove the tire completely from the wheel before you weld.

- Always have a qualified tire technician service the tires and wheels. If a tire has lost all pressure, take the tire and wheel to a tire shop or your dealer for service. Explosive separation of the tire can cause serious injury.

- Do not weld to a wheel or rim until the tire is completely removed. Inflated tires can generate a gas mixture with the air that can be ignited by high temperatures from welding procedures performed on the wheel or rim. Removing the air or loosening the tire on the rim (breaking the bead) will not eliminate the hazard. This condition can exist whether tires are inflated or deflated.

PERSONAL PROTECTIVE EQUIPMENT (PPE)

Wear Personal Protective Equipment (PPE) such as protective clothing, eye protection, hearing protection, dust mask, hard hat, heavy gloves, work boots, and/or any other PPE that provides for the safety and protection of the individual that operates or services this equipment.



2. SAFETY INFORMATION

SAFETY REQUIREMENTS FOR FLUID POWER SYSTEMS AND COMPONENTS - HYDRAULIC SYSTEMS

Before you start the engine or pressurize the hydraulic system, install and tight correctly all the hydraulic couplings. Check that all hoses and fittings are undamaged. Replace immediately damaged components.

Only connect the hydraulic hoses to the tractor outlets if the tractor and the implement are pressure-free. If the hydraulics of the tractor is activated it may lead to uncontrolled movements which may cause secondary damage.

Make sure that no persons are near the implement when you start the implement, as there might be air in the hydraulic system which might lead to sudden movements.

When the tractor engine has stopped, activate the tractor hydraulic spool valves to make sure that there is no pressure in the hydraulic hoses.

To expel all the air from the oil in the hydraulic cylinders, test all the functions after you connect the hydraulic connections to the tractor, especially before you enter or drive on the public roads. Otherwise, you risk that the cutting unit suddenly moves downward after you have dismantled the transport lock.

NOISE EMISSION

Use hearing protectors if the noise from the implement is annoying or if you work with the implement for a considerable period in a tractor cabin that does not have an adequate soundproof cabin.

2. SAFETY INFORMATION

IMPLEMENT STABILITY

The combination of your tractor and implement can become unstable, due to the additional weight that the implement adds to the tractor.

In order to guarantee stable and safe transport, you must check if you need ballast weights for transport and field work.

You must also check and guarantee that you have at least 20% from the tractor weight on the front axle. For rear mounted implements and front-rear combinations, the formula is:

$$I_{f,\min} = \frac{[I_r \times (c + d)] - (T_f \times b) + (0,2 \times T_e \times b)}{a + b}$$

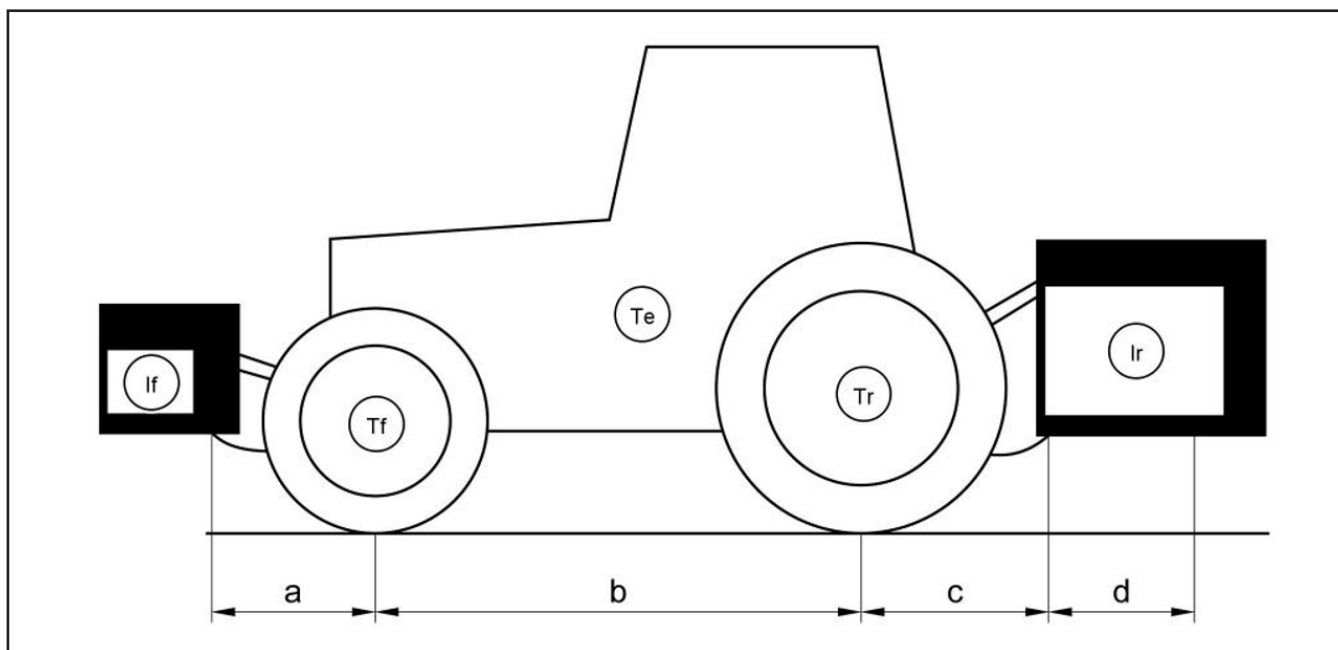

Example of references to stability of the combination tractor - implement.

List of signs:

Te [kg]	The tractor own weight.
Tf [kg]	Front axle load with empty tractor.
Tr [kg]	Rear axle load with empty tractor.
Ir [kg]	Total weight of the rear-mounted implement/rear ballast.
If [kg]	Total weight of the front-mounted implement/front ballast.
a [m]	Distance between the center of gravity of the front-mounted implement/front ballast and the middle of the front axle.
b [m]	The tractor wheel distance.
c [m]	Distance between the middle of the rear axle and the middle of the link arm balls.
d [m]	Distance between the middle of the link arm balls and the center of gravity of the rear mounted implement/rear ballast.

2. SAFETY INFORMATION

ECOLOGY AND THE ENVIRONMENT

Soil, air, and water quality is important for all industries and life in general. When legislation does not apply to the treatment of all the substances used, sound judgement should govern the use and disposal of products of a chemical and petrochemical nature.

Familiarize yourself with the relative legislation applicable to your country, and make sure that you understand this legislation. Where no legislation exists, obtain information from suppliers of oils, filters, batteries, fuels, anti-freeze, cleaning agents, etc., with regard to the effect of these substances on man and nature and how to safely store, use, and dispose of these substances. Your dealer can also provide assistance.

Helpful Hints

- Avoid the use of cans or other inappropriate pressurized fuel delivery systems to fill tanks. Such delivery systems may cause considerable spillage.
- In general, avoid skin contact with all fuels, oils, acids, solvents, etc. Most of these products contain substances that may be harmful to your health.
- Modern oils contain additives. Do not burn contaminated fuels and or waste oils in ordinary heating systems.
- Avoid spillage when you drain fluids such as used engine coolant mixtures, engine oil, hydraulic fluid, brake fluid, etc. Do not mix drained brake fluids or fuels with lubricants. Store all drained fluids safely until you can dispose of the fluids in a proper way that complies with all local legislation and available resources.
- Repair any leaks or defects in the hydraulic system immediately.
- Do not increase the pressure in a pressurized circuit as this may lead to a component failure.

Battery Recycling

Batteries and electric accumulators contain several substances that can have a harmful effect on the environment if the batteries are not properly recycled after use. Improper disposal of batteries can contaminate the soil, groundwater, and waterways. STOUT strongly recommends that you return all used batteries to a dealer, who will dispose of the used batteries or recycle the used batteries properly. In some countries, this is a legal requirement.



Mandatory Battery Recycling

NOTE: The following requirements are mandatory in Brazil.

Batteries are made of lead plates and a sulfuric acid solution. Because batteries contain heavy metals such as lead, CONAMA Resolution 401/2008 as amended by CONAMA Resolution 424/2010 requires you to return all used batteries to the battery dealer when you replace any batteries. Do not dispose of batteries in your household garbage.

Points of sale are obliged to:

- Accept the return of your used batteries
- Store the returned batteries in a suitable location
- Send the returned batteries to the battery manufacturer for recycling

2. SAFETY INFORMATION

SAFETY SIGNS

The following safety signs are on your implement as a guide for your safety and for the safety of those who work with you.

Walk around the implement and note the content and location of all safety signs before you operate your implement. Read all the safety decals adhered to the implement and follow the instructions.

Keep all safety signs clean and legible. Clean safety signs with a soft cloth, water, and a gentle detergent.

NOTICE: Do not use solvent, gasoline, or other harsh chemicals. Solvents, gasoline, and other harsh chemicals may damage or remove the safety signs.

Replace all safety signs that are damaged, missing, painted over, or illegible. If a safety sign is on a part that you or your dealer replaces, make sure that you or your dealer install the safety sign on the new part. Contact your dealer for the replacement of the safety signs.

Safety signs that display the “Read operator’s manual” symbol direct you to the operator’s manual for further information regarding maintenance, adjustments, or procedures for particular areas of the implement. When a safety sign displays the symbol, consult the appropriate page of the operator’s manual.



Safety signs that display the “Read service manual” symbol direct you to the service manual. If you doubt your ability to perform service operations, contact your dealer.



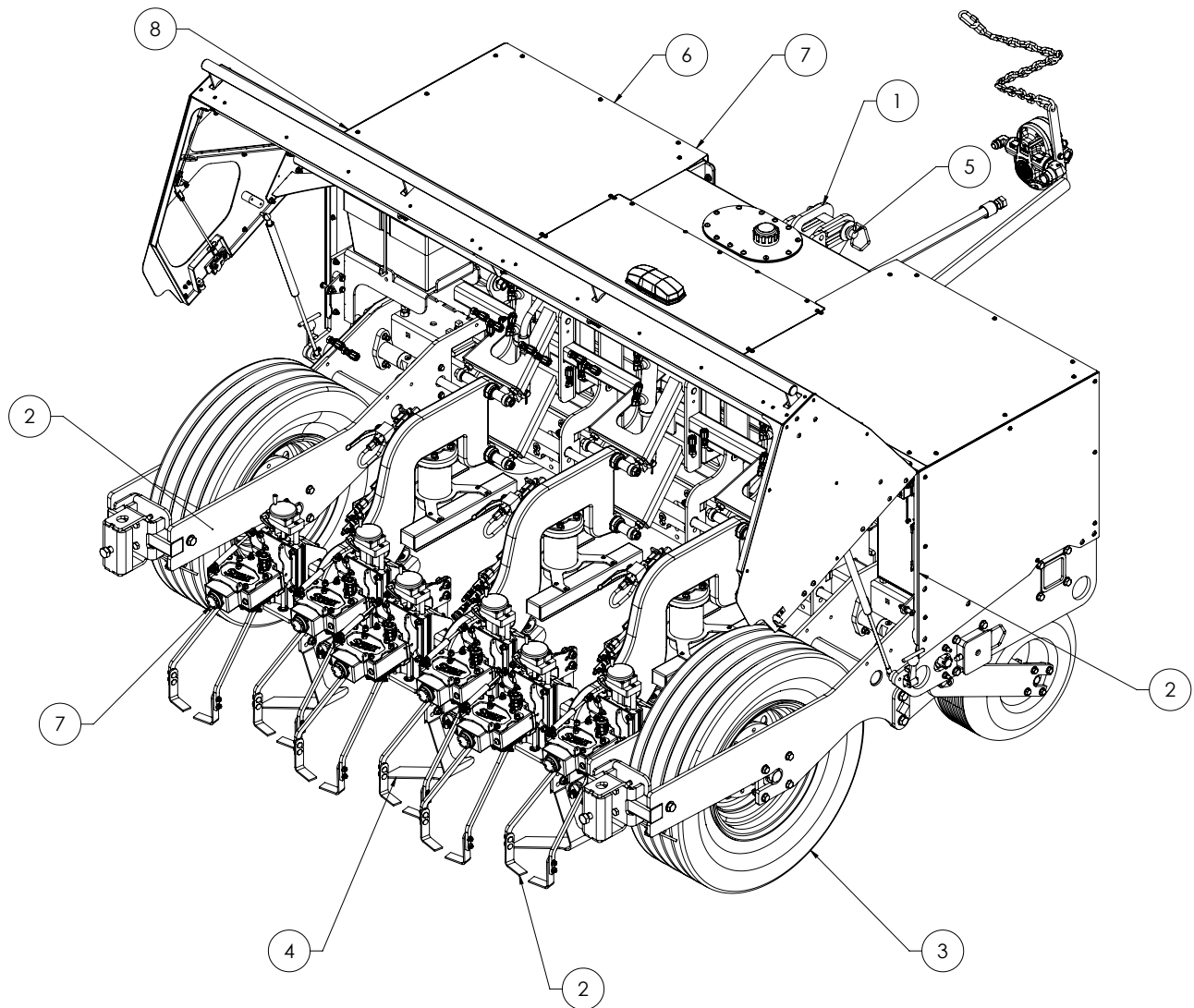

SAFETY LOCATION (1)

WARNING

Crushing hazard! Use the machine lifting points (Pg. 35) when you lift and/or move the machine with heavy handling equipment. Lift the machine only from the indicated lifting eye hookup points. Always use adequate lifting equipment. Failure to comply could result in death or serious injury.

2. SAFETY INFORMATION

SAFETY SIGN (2)

Keep hands away.

Never move your hand into the danger zone as long as the parts can move. The hazard could result in death or serious injury.



SAFETY SIGN (3)

Do not stand near the implement during lowering or leveling the implement.

Do not stand between the tractor and the implement or underneath the implement when operating the equipment. It may cause serious injuries.

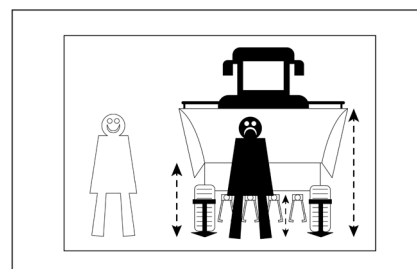

SAFETY SIGN (4)

Keep away.

There is a danger that you can be crushed by lowering the implement elements. The danger may cause severe injuries to the entire body. Keep clear of the implement's danger zone and pay attention to all other people standing next to the implement.

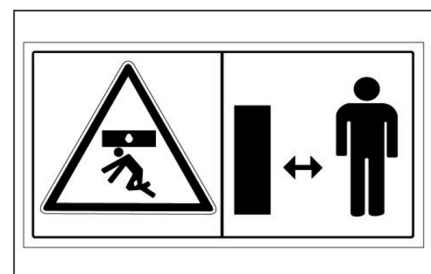

2. SAFETY INFORMATION

SAFETY SIGN (5)

A hazard of your body being crushed when standing between the tractor and the implement to be connected. The hazard could result in death or serious injury. When connecting the implement to a tractor, standing in between the implement and the tractor with the tractor engine running and the tractor not secured against accidental rolling is strictly prohibited.



SAFETY SIGN (6)

Maximum working pressure of the hydraulic system:
206 bar (3000 psi).

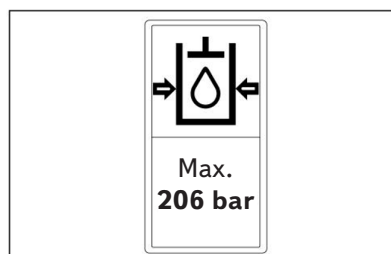

SAFETY SIGN (7)

Avoid pressurized outflowing of liquid. Danger generated by hydraulic oil out flowing under pressure. The danger may cause severe injuries to the entire body, with possible lethal effect. Before proceeding to maintenance procedures or repairs of the hydraulic system, make sure the system is depressurized. Do not try seal hydraulic oil leaks using your hands or fingers.



2. SAFETY INFORMATION

SAFETY SIGN (8)

WARNING ⚠

Avoid injury! Always do the following before lubricating, maintaining, or servicing the machine.

1. Disengage all drives.
2. Engage parking brake.
3. Lower all attachments to the ground, or raise and engage all safety locks.
4. Shut off engine.
5. Remove key from key switch.
6. Switch off battery key, if installed.
7. Wait for all machine movement to stop. Failure to comply could result in death or serious injury.

Stop the engine and take the key out of the ignition.



SAFETY NOTICE

WARNING ⚠

IMPROPER OPERATION OF THIS MACHINE CAN CAUSE DEATH OR SERIOUS INJURY. MAKE SURE THAT EVERY OPERATOR:

- Is instructed in the safe and proper use of this machine.
- Reads and understands the operator's manual for this machine.
- Failure to comply could result in death or serious injury.



SAFETY NOTICE

Attention! Moving modules. There is a danger that the modules could crush the body. The danger may cause severe injuries to the entire body, with possible lethal effect. To avoid danger, don't stand within the range of the modules. Before you move the modules, make sure that there are not people standing in its range.

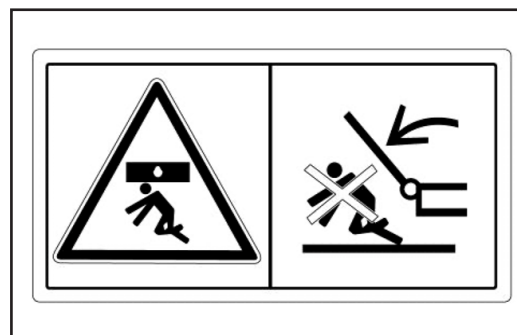

3. CONTROLS AND INSTRUMENTS

MONITOR

Touch Screen

1. The touch screen display is installed on the implement to change settings for the implement. The screen is powered on when the switch for the machine is turned to the ON position. Press the “START” button to continue. Read and observe the “DANGER” prompt on the Touchscreen. Press “I AGREE” to get to the Setup Screen.



TOUCH SCREEN TABS

Control Tab (Main Screen)

The available menus are located on the top of the screen and can be accessed by touching the respective buttons on the touch screen display.

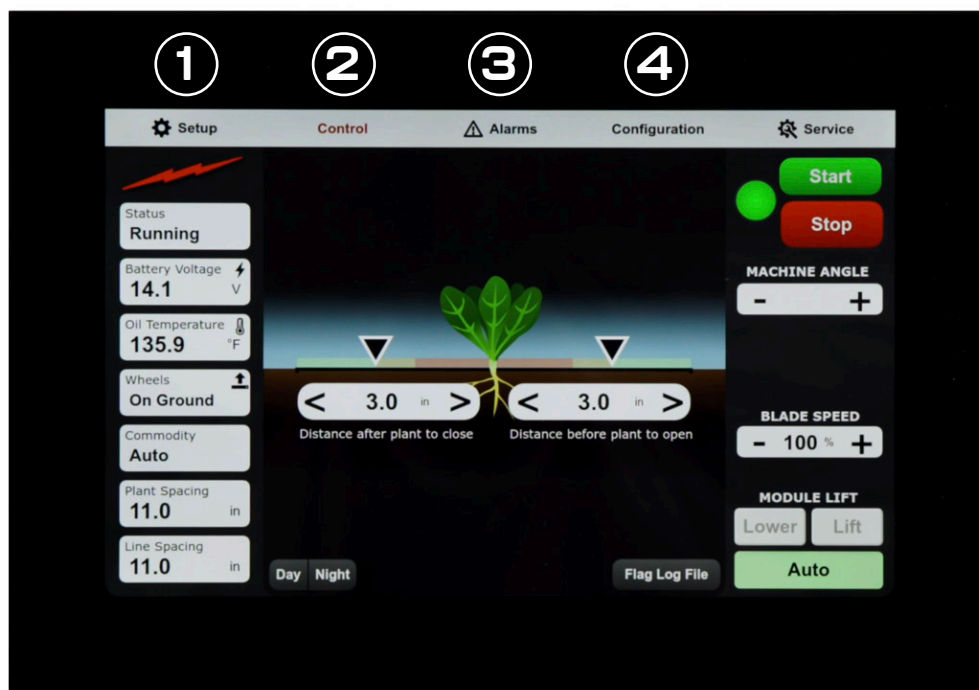

Touchscreen Tab	Function
1. Setup	Select commodity and configure plant bed configurations
2. Control	Main screen that displays current machine information and actuator blade configuration settings
3. Alarms	Shows current alarms and network status of machine
4. Configuration	Configure pressure settings and test side shift

3. CONTROLS AND INSTRUMENTS

MAIN SCREEN OUTLINE

1. Current settings setup for the machine
2. Set distances for opening and closing of actuator blades before and after the plant
3. Start/Stop of machine operating
4. Setting the angle of the machine
5. Speed of the actuators opening and closing
6. Manually lift and lower modules when Auto Button is Disabled
7. Enables/Disables the Auto lift and lower for the modules

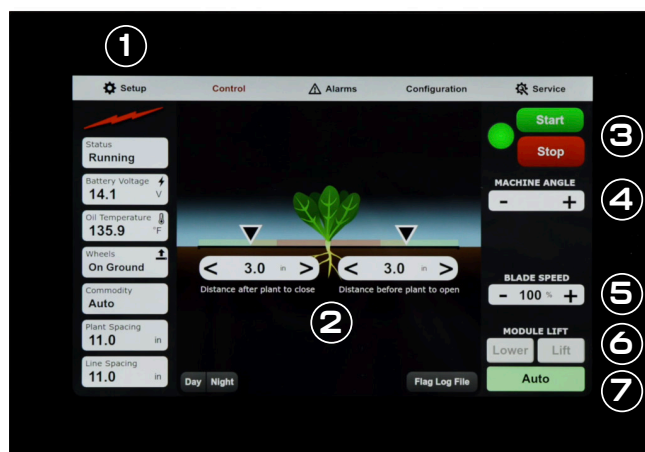

SET UP TAB

1. Commodity: Select commodity the implement will be working through
2. Plant Spacing: Set plant spacing between plants on the same line
3. Line Spacing: Set plant row spacing between rows of plants
4. Machine Size: Set wheel furrow spacing
5. Modules Enabled: Select modules to be used for operation
6. °C(°F)/cm (inch)/Bar(PSI): Select units to be displayed



ALARMS TAB

1. Electrical System: Shows current active alarms
2. Computers/Vision/Network: Colored bubbles show status of the different systems for a particular module.
3. Clear Alarms: Press button to clear alarms that are showing in the Electrical System. See Guide to Fault Table (Pg.32) for details on alarms

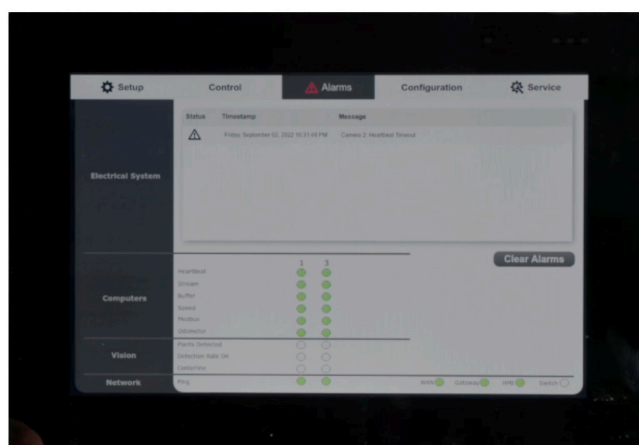

3. CONTROLS AND INSTRUMENTS

CONFIGURATION TAB

1. Ground Pressure System: Settings to setup Ground Pressure System
2. Side Shift: Manually side shift module brackets
3. Lift Detection: Enabling and disabling automatic lift detection

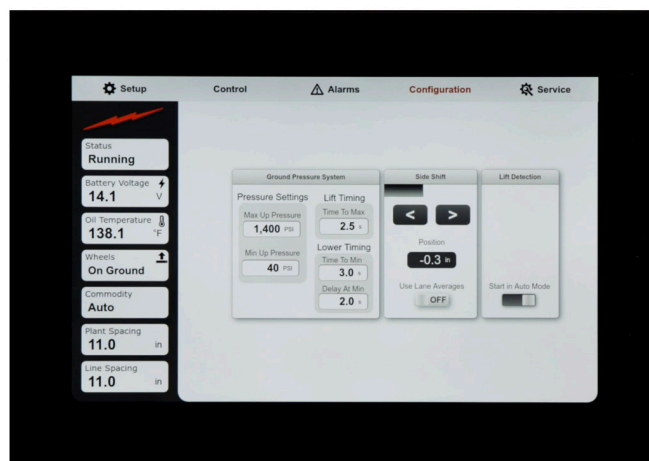

SERVICE TAB

1. Login for Stout Certified Technicians to service machine.
2. Actuator Test: Set a test to run actuators to ensure they are opening and closing properly. Press the “Enable Actuator Test” button when ready to run the test
3. Machine Information: Machine serial number and current software version can be found here.

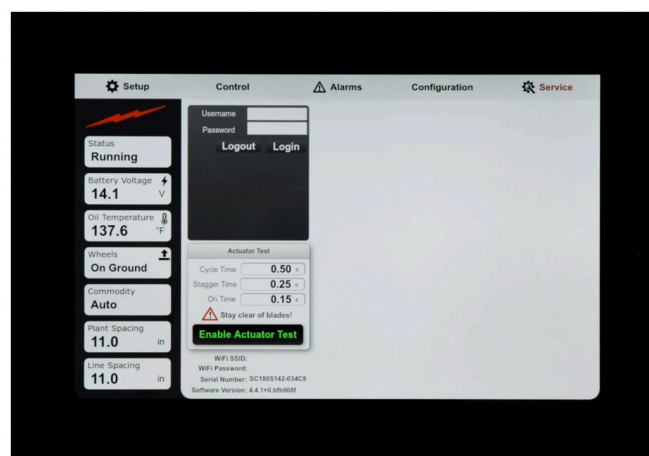

3. CONTROLS AND INSTRUMENTS



FAULT TABLES

Alarm Message	Meaning	Possible Causes
Battery Voltage Too High (Overcharging)	The battery voltage exceeds 14.7 volts.	<ul style="list-style-type: none"> - Loose or damaged alternator ground wire - Loose or damaged battery ground wire - Faulty alternator - A battery charger was connected to the machine and it charged the battery above 14.7 volts. This is OK if only for a short period of time.
Heartbeat Timeout	The camera computer stopped communicating with the controller for a period of time.	<ul style="list-style-type: none"> - Loose or damaged cable between camera and computer - Loose or damaged cable between computer and ethernet switch - Loose or damaged cable between ethernet switch and controller - Faulty power wiring to computer - Faulty power wiring to ethernet switch - Faulty power wiring to camera - A software update was applied which caused the computer to restart
Stream Processing Error	The camera computer encountered an error while processing images.	<ul style="list-style-type: none"> - Faulty camera cable - Software error
Machine did not complete initialization in the expected time	The camera computers failed to start or took longer than the normal amount of time to start.	<ul style="list-style-type: none"> - A software update was applied, which required the computers to take longer to start up. - Any of the causes for "Heartbeat Timeout" can also cause this alarm.
Battery Sense Low	The machine controller is sensing an implausibly low battery voltage (less than 7 volts).	<ul style="list-style-type: none"> - Faulty connection between controller and battery voltage sense wire. - Faulty controller.
Voltage Regulator Malfunction: Low	The machine controller is detecting a system voltage regulator output of less than 22.0 volts.	<ul style="list-style-type: none"> - Faulty 24V voltage regulator wiring - Faulty 24V regulator
Voltage Regulator Malfunction: High	The machine controller is detecting a system voltage regulator output of greater than 25.0 volts.	<ul style="list-style-type: none"> - Faulty or missing ground wiring - Faulty 24V regulator
Odometer Pulse Rate High	The pulse rate coming from the wheel encoder is implausibly high.	<ul style="list-style-type: none"> - Faulty wheel encoder wiring - Faulty wheel encoder
Hydraulic Fluid Level Low	The low oil level sensor in the tank is not detecting any liquid.	<ul style="list-style-type: none"> - Oil level is low - Faulty sensor wiring - Faulty sensor
Oil Temperature Low	The oil temperature sensor reading is implausibly low.	<ul style="list-style-type: none"> - Faulty sensor wiring - Faulty sensor
Oil Temperature High	The oil temperature sensor reading exceeds 115C (239F).	<ul style="list-style-type: none"> - Clogged radiator - Faulty fan - Faulty hydraulic system - PTO pump too large - PTO pump spinning too fast - Faulty 12V battery - Faulty temperature sensor wiring - Faulty temperature sensor

3. CONTROLS AND INSTRUMENTS



FAULT TABLES

Alarm Message	Meaning	Possible Causes
Shift Position Sensor Glitch / Rate of Change High	The shift position sensor moved faster than should be possible.	<ul style="list-style-type: none"> - Clogged radiator - Faulty fan - Faulty hydraulic system - PTO pump too large - PTO pump spinning too fast - Faulty 12V battery - Faulty temperature sensor wiring - Faulty temperature sensor
Shift Sensor Type Not Set	The type of side shift sensor has not been configured.	<ul style="list-style-type: none"> - Incomplete configuration of machine or settings lost.
Side shift CAN module error	The controller is unable to communicate with the side shift sensor on the CAN bus.	<ul style="list-style-type: none"> - Faulty CAN bus wiring - Incorrect sensor type configured - Incorrect sensor CAN bus node ID - Faulty sensor
Ground Pressure Sensor Malfunction (high or low) / Module Lift Pressure Sensor Malfunction (high or low)	The module lift manifold pressure sensor has an implausibly high or low reading.	<ul style="list-style-type: none"> - Faulty sensor wiring - Faulty valve cartridge - Faulty pressure sensor
Ground Height Sensor Malfunction	The height control wheel angle sensor reading is implausibly high or low.	<ul style="list-style-type: none"> - Misaligned sensor puck - Faulty sensor wiring - Faulty sensor
Machine Settings Uninitialized	The settings for the machine are incomplete.	<ul style="list-style-type: none"> - Incomplete configuration - Settings were lost
Plant Location buffer overflow	Internal software error: too many plants were received by the controller.	<ul style="list-style-type: none"> - Software error Internal software error: too many plants were received by the controller. - Implausibly high number of plants detected by vision system
Latency too high for travel speed	Machine being operated too fast for the cameras	<ul style="list-style-type: none"> - Machine running at too fast of a speed - Faulty wheel encoder
Modbus Communication Error	Communication problem between camera computer and main controller.	<ul style="list-style-type: none"> - Faulty ethernet cable between vision computer and ethernet switch - Fault ethernet cable between ethernet switch and controller - Faulty ethernet switch - Software error
High Processing Latency	Processing problem internal to the camera computer	<ul style="list-style-type: none"> - Faulty ethernet cable between camera and vision computer - Software error - Faulty ethernet cable between vision computer and ethernet switch - Faulty ethernet switch - Faulty ethernet cable between ethernet switch and controller
Height Control Disabled	The height control system is disabled.	<ul style="list-style-type: none"> - Incomplete configuration - Settings were reset

3. CONTROLS AND INSTRUMENTS



FAULT TABLES

Alarm Message	Meaning	Possible Causes
Applicator unstable pressure or flow rate during calibration	Calibration failed due to pump pressure being unstable.	<ul style="list-style-type: none"> - Air in supply lines or tank empty - Faulty pressure regulator - Supply valve closed or hose clogged - Return valve closed or hose clogged - Plumbing leak - Air in lines - Faulty pressure sensor wiring - Faulty pump - Faulty pump wiring - Faulty battery - Faulty alternator
Applicator pressure out of bounds	Pump pressure was outside the expected range while the pump was on.	<ul style="list-style-type: none"> - Manual pressure regulator set incorrectly - Faulty pressure regulator - Air in supply lines or tank empty - Supply valve closed or hose clogged - Return valve closed or hose clogged - Plumbing leak - Air in lines - Faulty pressure sensor wiring - Faulty pump - Faulty pump wiring - Faulty battery - Faulty alternator
Applicator pressure exceeds limit	The pump pressure is too high.	<ul style="list-style-type: none"> - Manual pressure regulator set incorrectly - Faulty pressure regulator - Faulty pressure sensor wiring
Applicator flow sensor fault	The flow sensor is faulty or disconnected.	<ul style="list-style-type: none"> - Faulty flow sensor wiring - Faulty flow sensor
Applicator flow rate too high	The flow sensor is faulty or wiring is shorted.	<ul style="list-style-type: none"> - Faulty flow sensor wiring - Faulty flow sensor
Applicator nozzle flow rate too low for prescription	The nozzle flow rate is too low to supply enough volume to some plants at the current spacing.	<ul style="list-style-type: none"> - Nozzles are too small - Applicator pressure set too low - Prescription volume is too high
Applicator disabled to prevent exceeding max rate	The applicator system would have dispensed more than the max rate limit and was shut off.	<ul style="list-style-type: none"> - More plants than expected - Prescription volume too high - Max rate limit too low
Sensor voltage supply malfunction	Sensor voltage supply is out of range.	<ul style="list-style-type: none"> - Shorted sensor wiring - Faulty sensor - Faulty controller
Sensor supply voltage low (5V)	Sensor supply voltage is out of range	<ul style="list-style-type: none"> - Shorted sensor wiring - Faulty sensor - Faulty controller

4. OPERATING INSTRUCTIONS

CONNECTION TO THE TRACTOR

WARNING

Pressurized system! Before removing the attachment from the machine, make sure the air pressure and hydraulic oil pressure are at zero. Failure to comply could result in death or serious injury.

Use only tractors specified in the operator's manual as recommended for connecting the implement.

To mount the implement on the tractor, the implement is equipped with a 3 point hitch.

The top link can be adjusted in the optimal way in relation to the tractor make, model and 3-point hitch category.

Correctly adjust the lower link arm brackets of the implement so that the implement follows the tractor correctly.

Before you connect the implement, control all coupling elements, inspect the implement for cracks, loose screws or nuts, or parts missing. Always make sure that the implement will not accidentally disconnect from the tractor during field works.

NOTICE: Due to the weight of the implement and its distance of the center of gravity behind the tractor, the top link is high loaded. Make sure, that the used top link is fully functional and that there are no damages at its hook. In cases of doubt replace the top-link. If it is damaged or excessively worn, replace the top link. Only use STOUT spare parts.

Connect the implement to the tractor in dedicated places only.

Connecting the implement to the tractor

Before you connect the implement to the tractor:

- Verify if the connection matches the three-point suspension system of the implement and the tractor.
- Perform all the necessary adjustments if the connection is inconsistent.
- Make sure that the implement stands on a firm and even ground.

WARNING

Hitching hazard! Always keep the area between the tractor and the implement clear of all persons while the tractor or three-point hitch is in motion. Lock the tractor transmission in Park and engage the parking brake(s) before you allow anyone to complete hitching or unhitching. Failure to comply could result in death or serious injury.

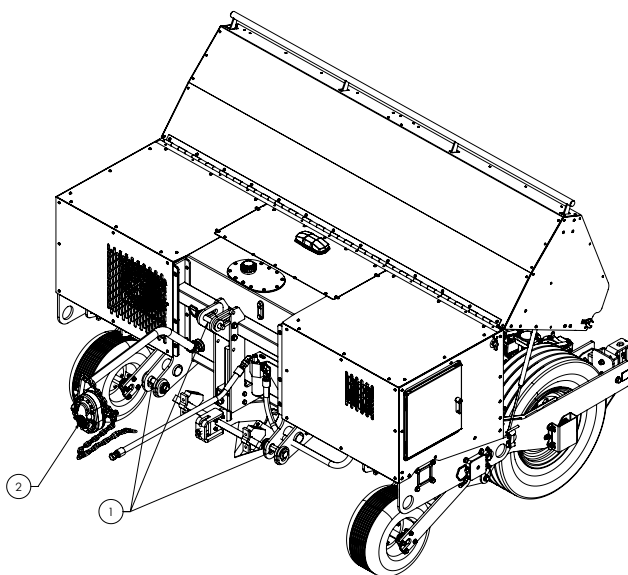

4. OPERATING INSTRUCTIONS

To connect the implement to a three-point suspension system of the tractor, proceed as follows:

1. Lower the lower linkages and reverse the tractor to place the hooks of the lower linkages under the ball sleeves.
 2. Place the correct ball couplings on the pivot of the connecting rod.
 3. Secure all the connections to avoid unintentional disconnection.
- NOTE:** The connections must be as tight and stiff as possible.
4. Mount the top link so that it is approximately parallel with the link arms. The top link should have some play while in operation. While transporting with tractor, the top link should be tight.

5. Make sure that all hydraulic connections are clean and then make all the necessary hydraulic connections.

NOTE: Keep the correct oil flow direction.

6. Inspect the implement for any leaks from hydraulic connections.
7. Check if all devices are fully operational.
8. Hook up PTO pump to PTO shaft of tractor. Use chain from PTO to ensure the pump does not move while it is engaged and powered by PTO shaft.

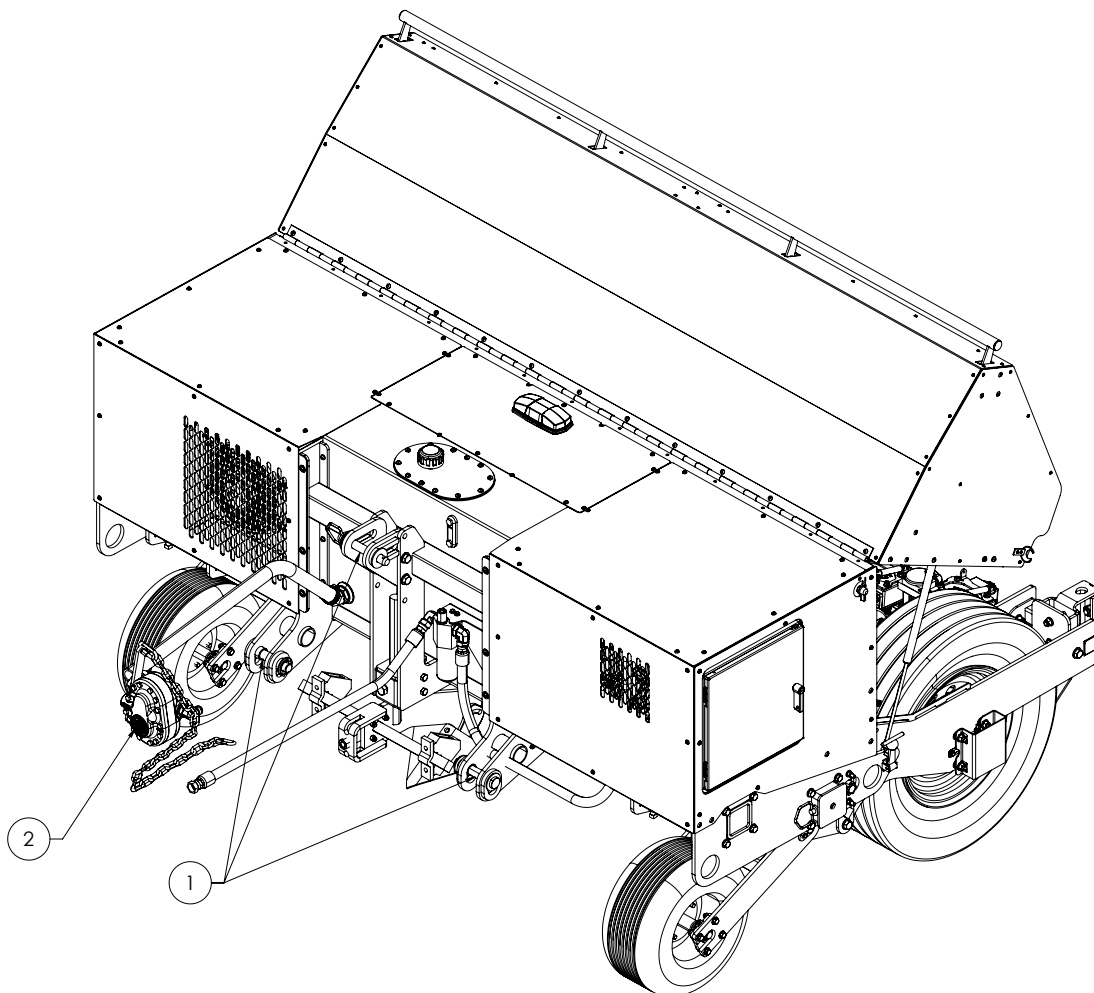

4. OPERATING INSTRUCTIONS

NOTES BEFORE BEGINNING PROCEDURE:

- 540 RPM shaft on the tractor is a 6 spline
- 1000 RPM shaft on the tractor is 21 spline
- Operator needs to read tractor manual to know how to select & engage correct option between 540 RPM or 1000 RPM (cannot select 540 RPM option on the tractor with a 1000 RPM shaft physically installed, and vice versa).
- Whether 540 RPM or 1000 RPM – once PTO is engaged, tractor RPM need to be set at 2000 RPM. RPM cannot fluctuate during operation, they need to remain at 2000 RPM while implement is on.

START UP PROCEDURE

1. Start the tractor.
2. Ensure that the 540-1000 PTO speed selector (if equipped) is set to 1000 RPM.
3. Engage the PTO.
4. Increase the tractor engine RPM until the PTO shaft speed is 1000 RPM.
5. Turn on the implement main switch.
6. Turn the module lift valve levers to the locked position (up).
7. Go to the Control section on the touchscreen.
8. Wait for Status (on the left side of the touchscreen) to change from “Initializing” to “Ready”.

This will require up to 3 minutes to complete.

9. Press the Start button to engage the hydraulic controls and actuator controls.

SHUT DOWN PROCEDURE

1. Using the touchscreen, open the Control page.
2. If Auto is illuminated and active, press Auto to disable it.
3. Using the touchscreen, press and select Lift.
4. Once the modules are raised, turn the module lift levers to the up and locked position.
5. Using the touchscreen, press and select Stop.
6. Turn off the main shut off switch.
7. Turn off the tractor PTO.

4. OPERATING INSTRUCTIONS

CONFIGURATION HOW TO: SPACING OUT THE GAUGE WHEEL FOR DIFFERENT SIZED BEDS

WARNING! Do not have the tractor or the implement running while completing the following steps. Confirm that everything is off. Take all necessary measures to ensure that anyone working on the configuration of the implement can do so safely.

STEP 1: Loosen the lead screws located on the acme thread until they are rotating freely. Loosen all the lead screws on the machine except one lead screw on each of the big gauge wheels (see arrows below).

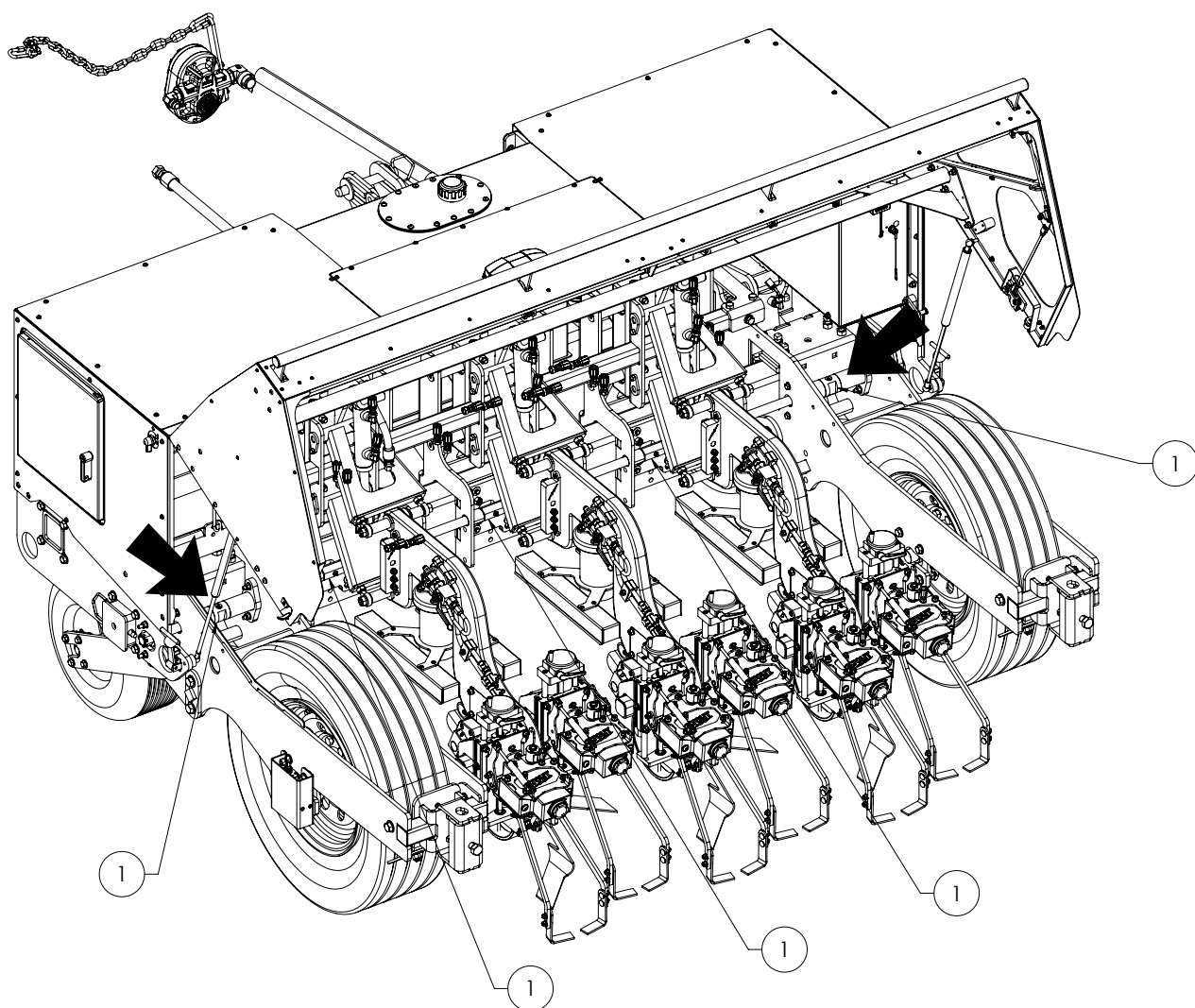

4. OPERATING INSTRUCTIONS

NOTE: The spacing from the center wheel to wheel is factory set to 80". If it was shifted before, marking off the spacing of the brackets is recommended (using a paint pen) before you begin the shifting procedure.

Shift each wheel in the same increments. For example: If the wheel spacing distance is being set to 213.36 cm (84 in) from 203.2 cm (80 in), move each wheel out 5.08 cm (2 in). If the wheel spacing distance is being set to 193.04 cm (76 in) from 203.2 cm (80 in), bring each wheel in 5.08 cm (2 in).

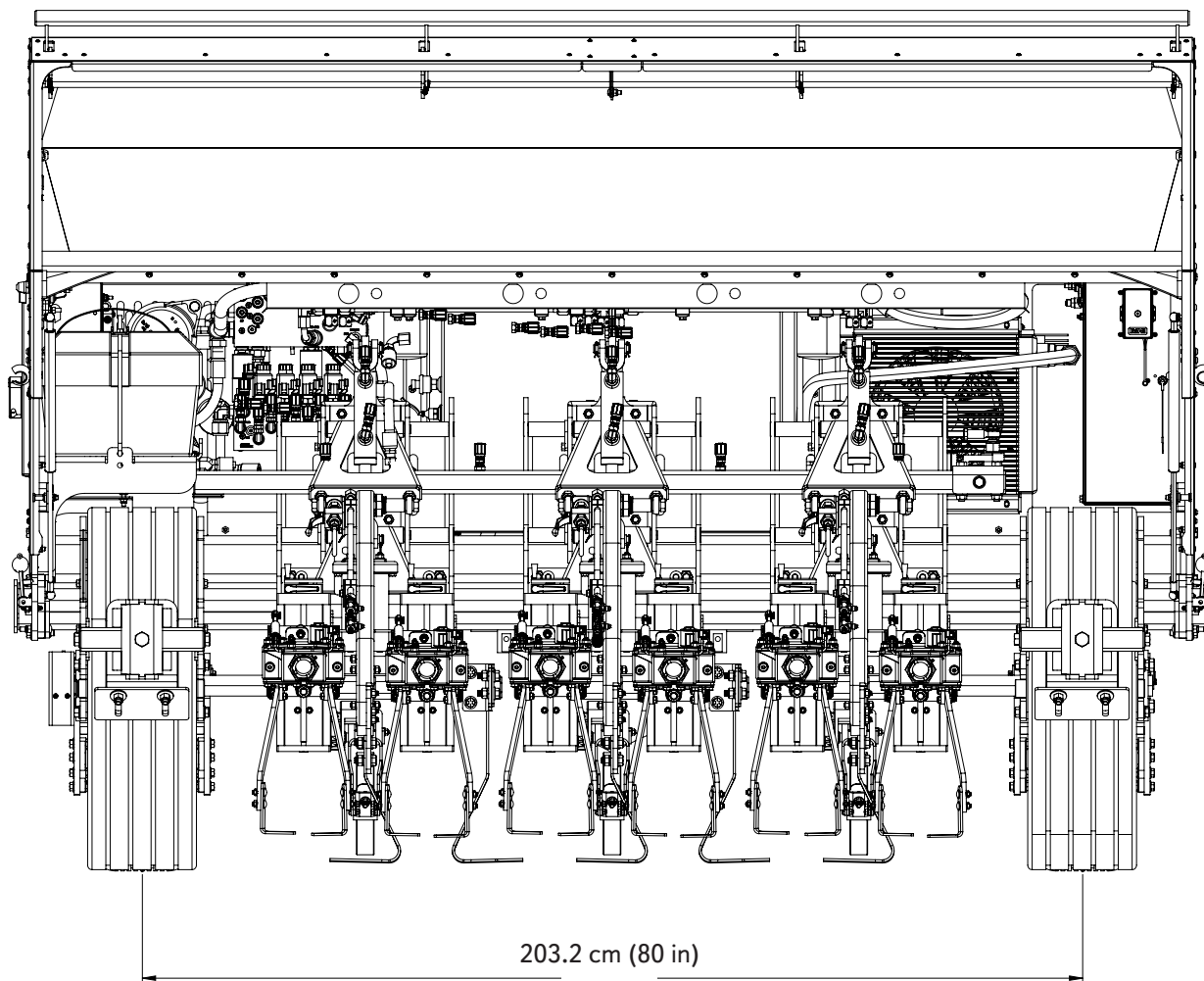

4. OPERATING INSTRUCTIONS

STEP 2: Loosen all of the nuts and bolts located on the gauge wheel bracket. (There are a total of 16) Loosen each nut using a 15/16 in deep socket. After loosening the nuts, loosen the square bolts. It is recommended to use a 3/4 in 12-point socket. It is also recommended to use a 24 in swivel extension for the nuts that are difficult to reach.

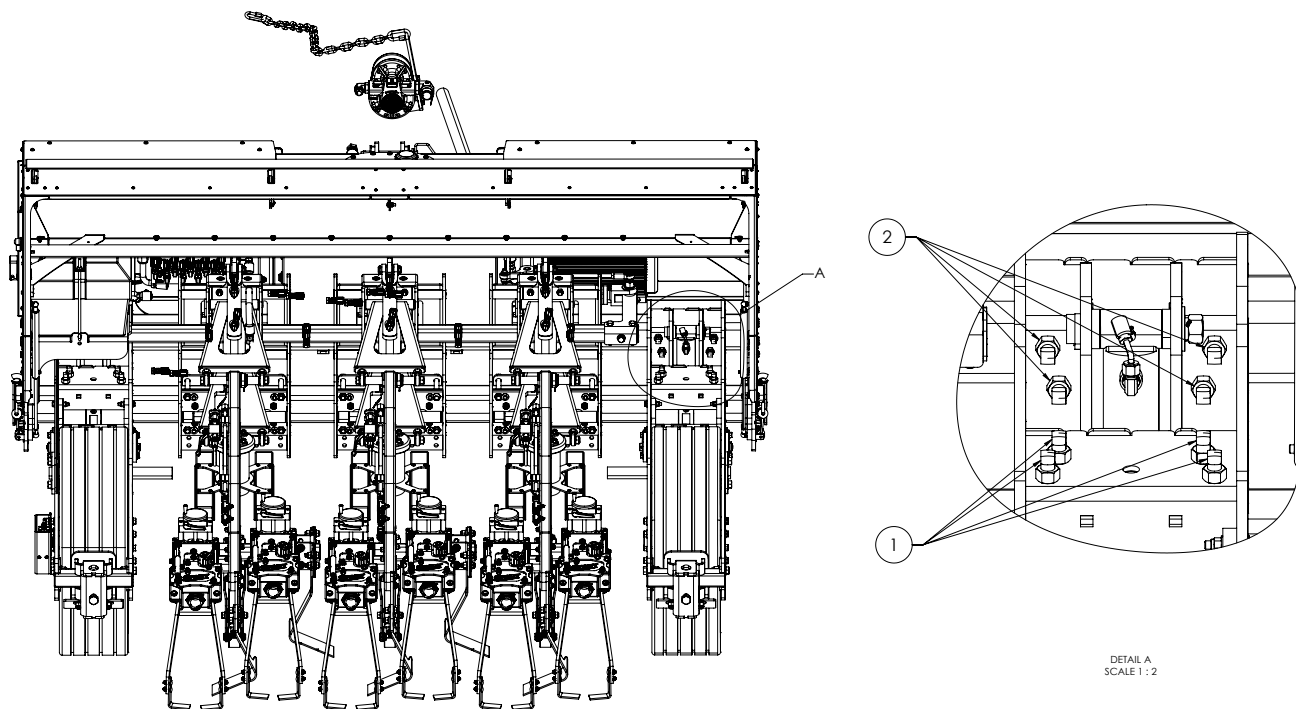

4. OPERATING INSTRUCTIONS

The nuts and bolts are located under the machine. Follow the same steps as the previous page. Once all the nuts and bolts are loosened, proceed to the next steps.

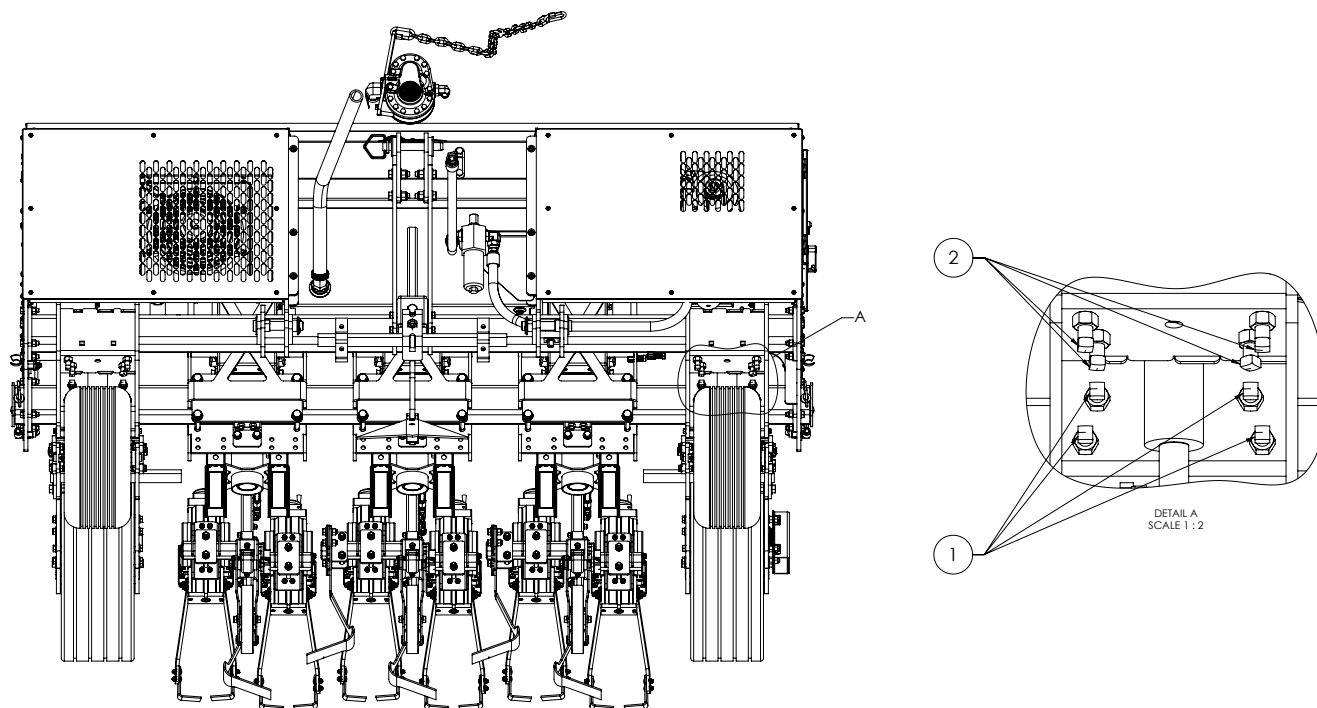

4. OPERATING INSTRUCTIONS

NOTE: It is recommended to have two people assist with the following steps.

STEP 3: Using a 1 3/8 in socket, turn the nut located on the outside of the machine. The nut will rotate the lead screw that is located on both the left and the right side. Only one side needs to be turned and either side can be chosen.

NOTE: Rotating the nut clockwise will draw the wheel closer to your position. Rotating the nut counterclockwise will push the wheel away from your position. Every 5 full turns is approximately 2.54 cm (1 in).

As the nut is being rotated (A), place a crescent wrench on the lead screw of the gauge wheel (B) that is being shifted (To ensure this is properly tighten, it is recommended a second person assist for this step). Once the desired spacing on that gauge wheel is reached, follow the previous steps to shift the other gauge wheel.

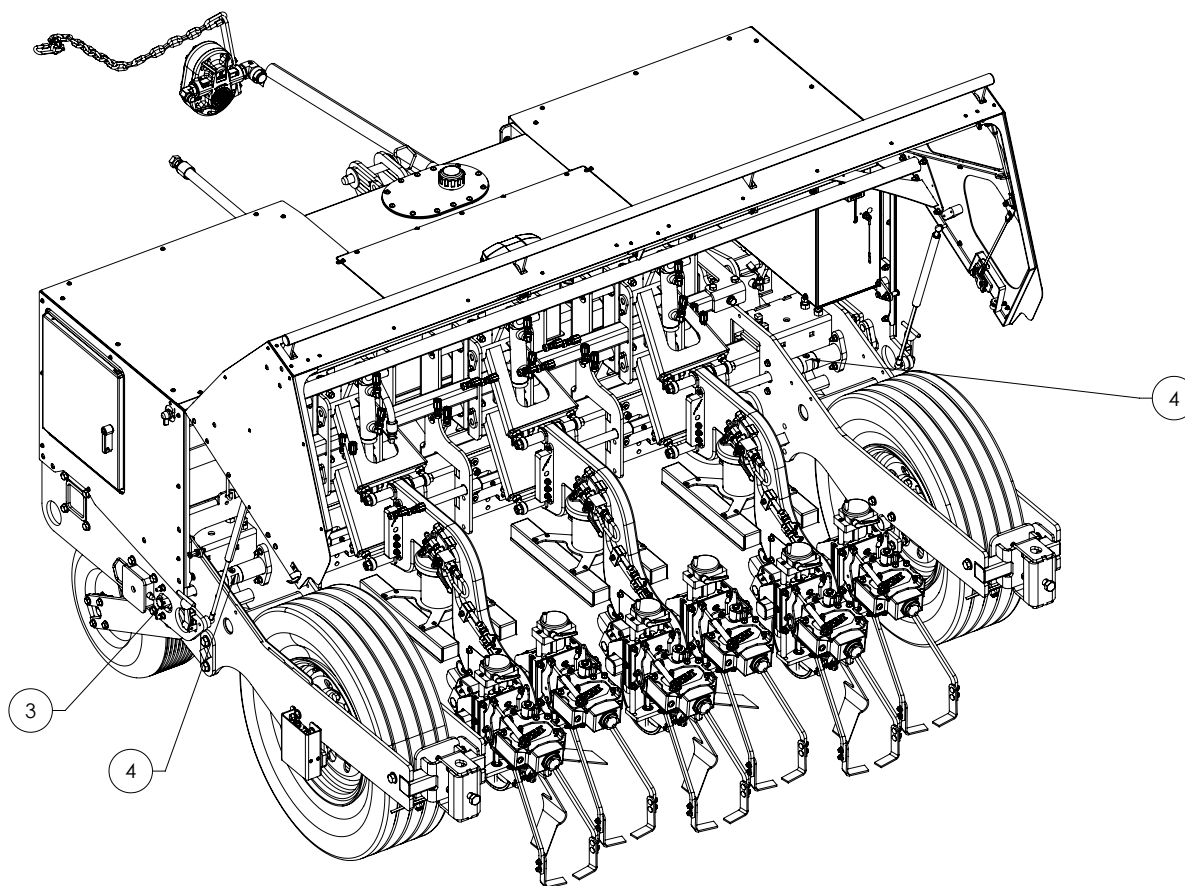

4. OPERATING INSTRUCTIONS



STEP 4: Once the wheels are properly spaced, verify all of the nuts and bolts on the gauge wheel bracket that were loosened are re-tightened.

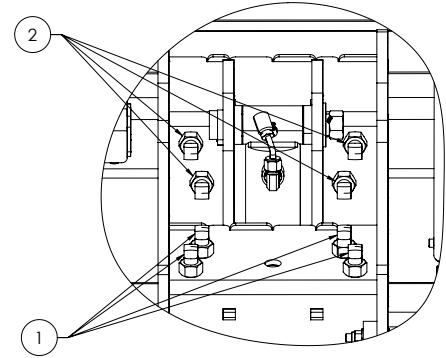
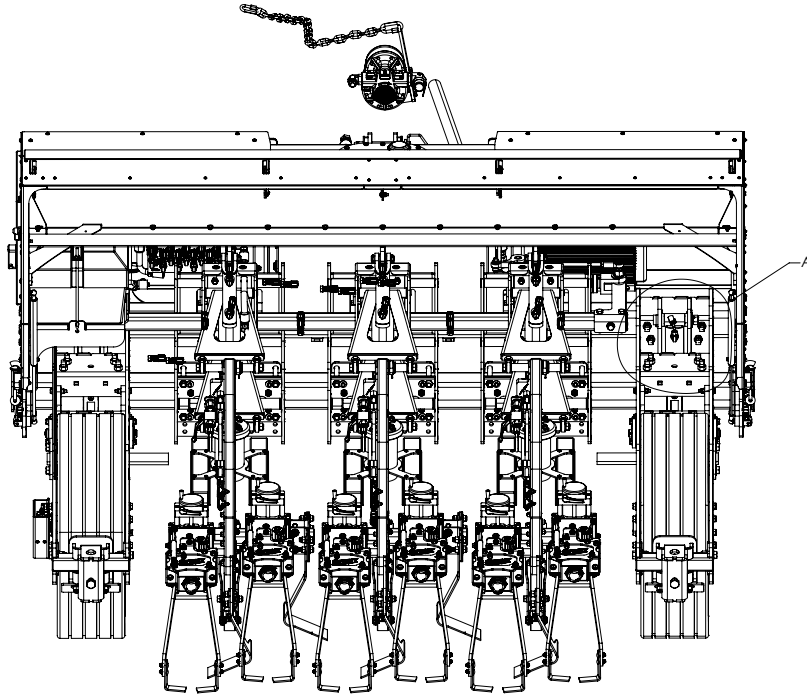

DETAIL A
SCALE 1 : 2

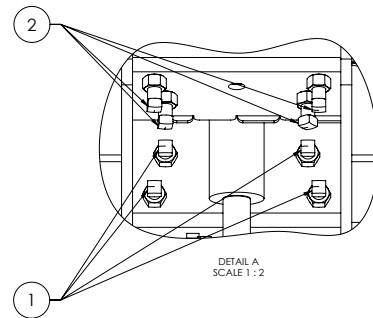
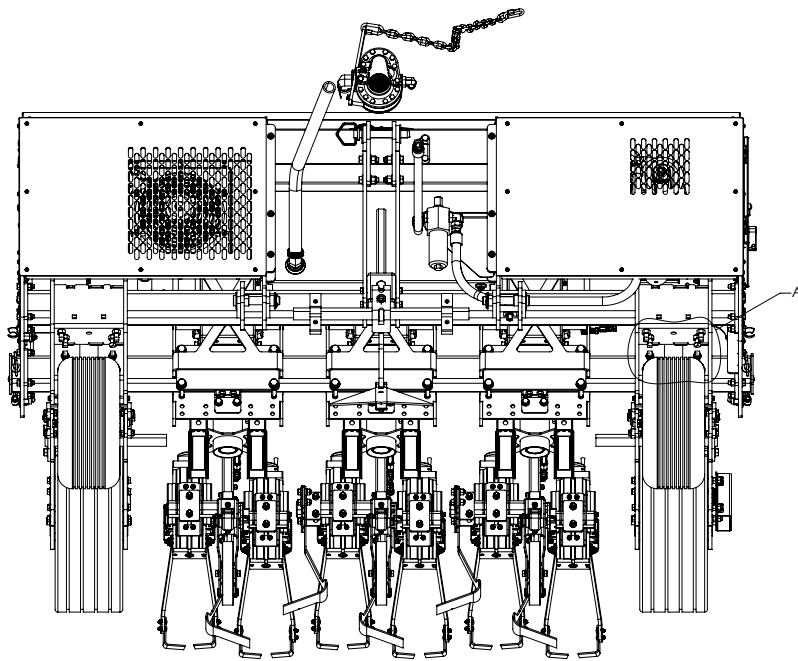

DETAIL A
SCALE 1 : 2

4. OPERATING INSTRUCTIONS

CONFIGURATION HOW TO: 6 LINE TO 5 LINE SET UP

WARNING! Do not have the tractor or the implement running while completing the following steps. Confirm that everything is off. Take all necessary measures to ensure that anyone working on the configuration of the implement can do so safely.

CAUTION: Before starting the following steps, ensure the “Side Shift” is positioned at 0.0 - 0.3 on the touchscreen. If it is not positioned at 0.0 - 0.3 misalignment of all the backbones may occur and require starting over.

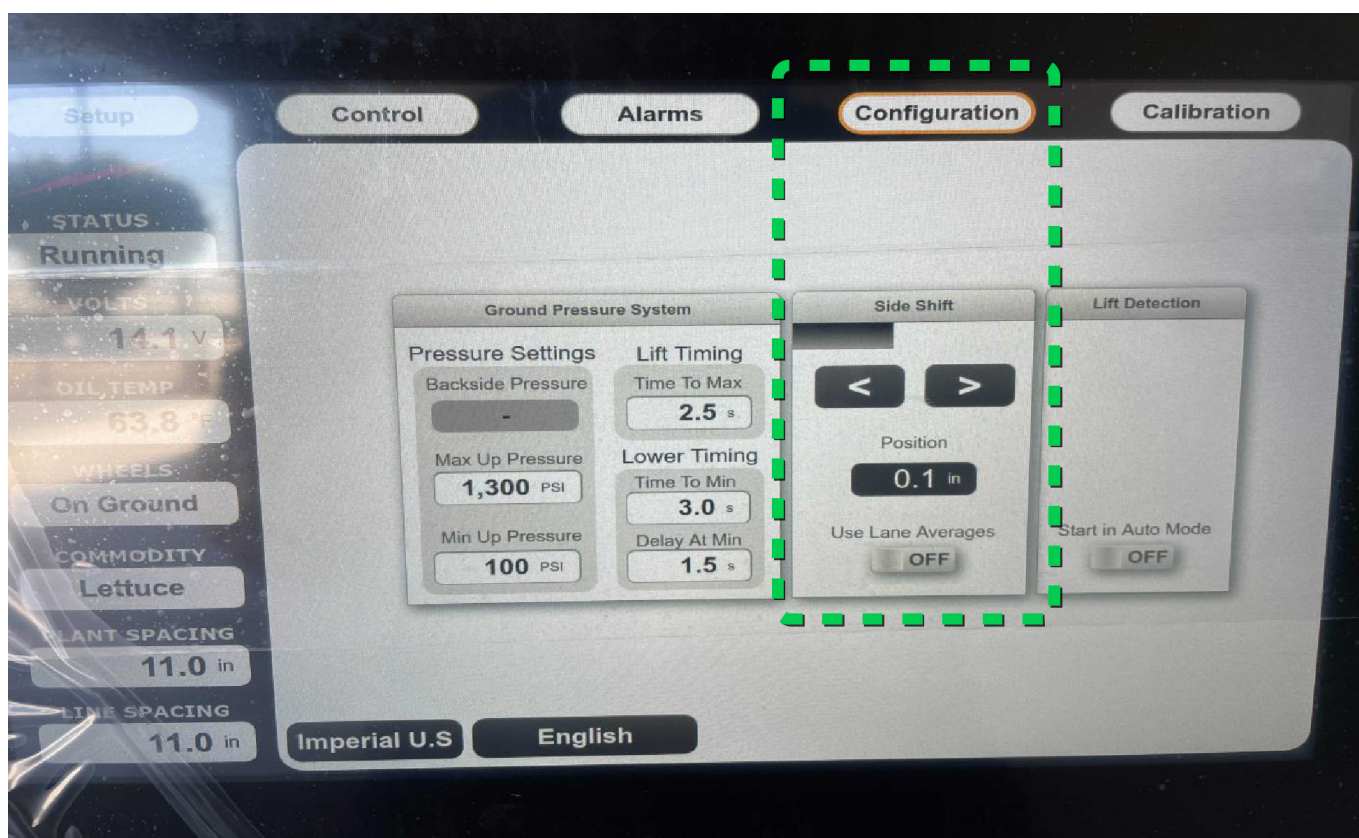

4. OPERATING INSTRUCTIONS

STEP 1: Begin by removing actuator 3. Unplug the hydraulic lines and associated electrical solenoid plug. Next, remove the actuator from the bar (see green arrow). Remove the bar by undoing the 4 bolts (see red arrow). Loosen actuator 4 and move it in. Remove the bracket that holds the cultivation sweeps in between actuators 2 & 3 (see light blue arrow). A 9/16 in and 3/4 in wrench is required to complete this step.

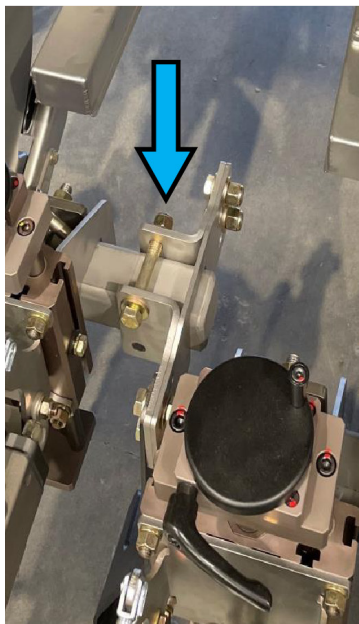
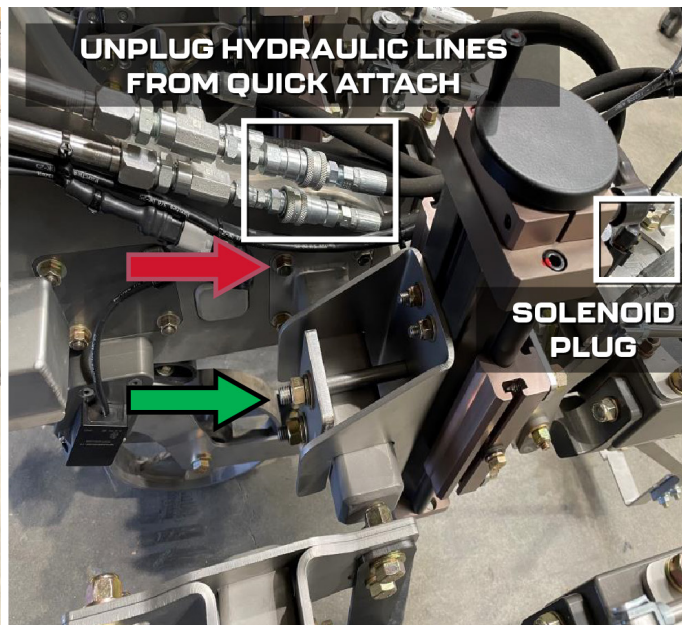
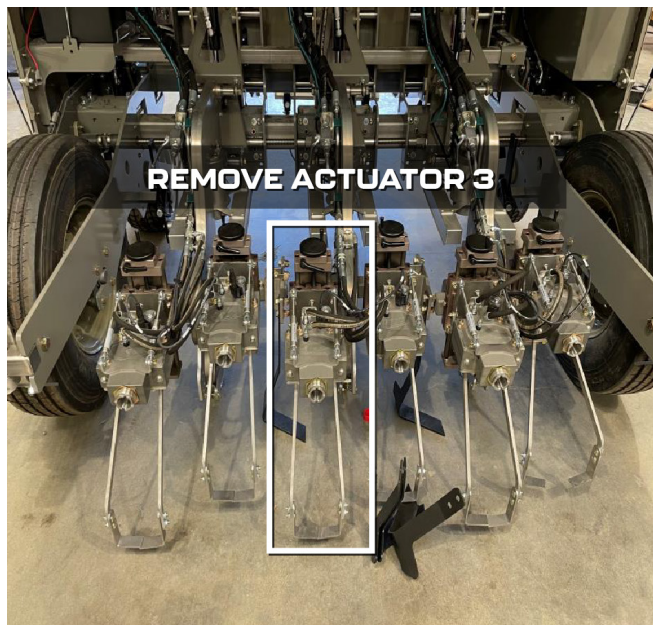

4. OPERATING INSTRUCTIONS

STEP 2: Backbone 1 will need to shift right. Backbones 2 & 3 will need to shift left. To shift these backbones, break loose the back plate on the 2 in (5.08 cm) bar and the 4 bolts on the 4 in (10.16 cm) bar - this will require crawling and working under the machine. A 15/16 in wrench an 15/16 in deep socket with a ratchet is recommended to complete this procedure.

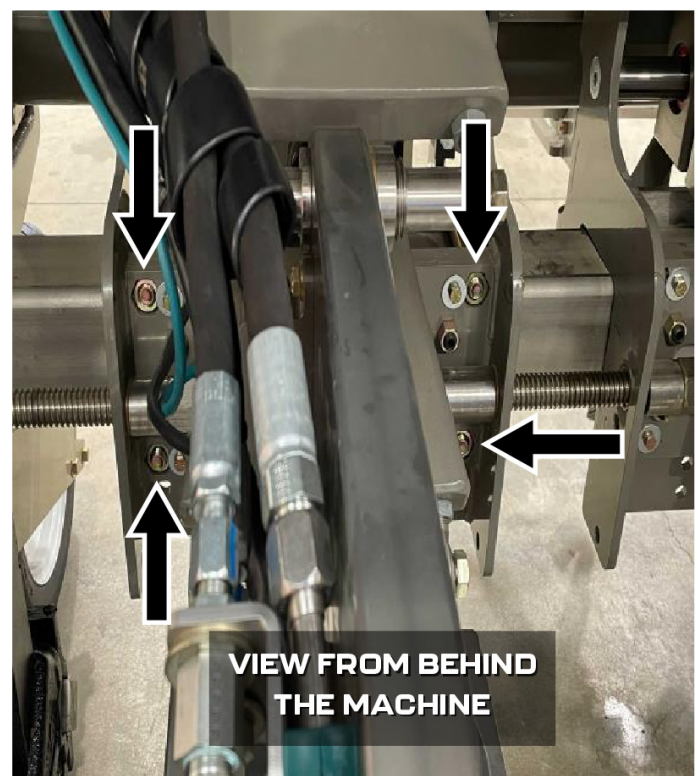
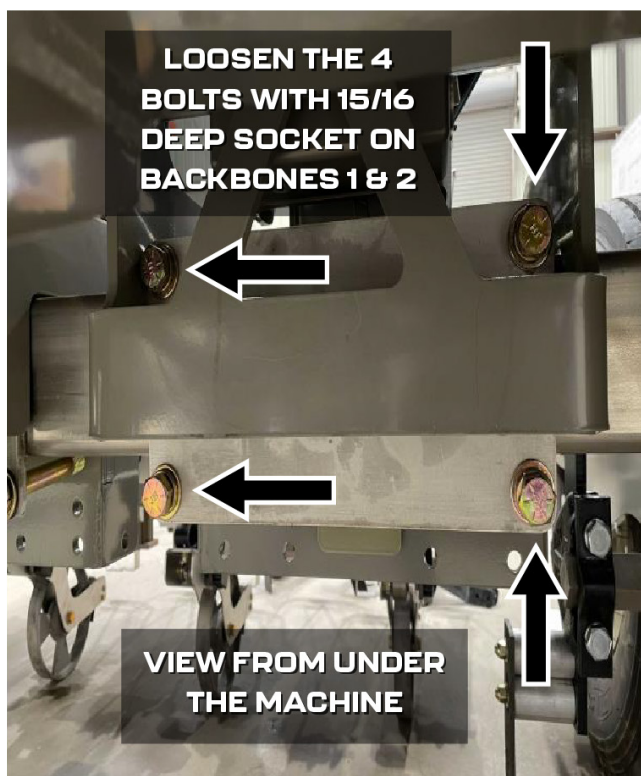
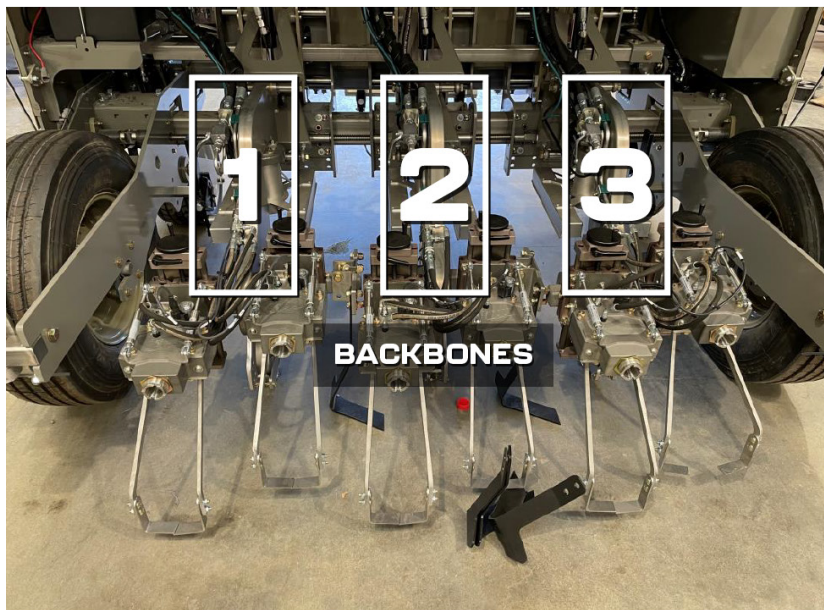

4. OPERATING INSTRUCTIONS

STEP 3: Loosen the lead screws located on the acme thread until they are rotating freely. There are 4 screws - 2 located near the big gauge wheels and 2 under backbones 1 & 3. It is recommended to use an adjustable crescent wrench for this step.

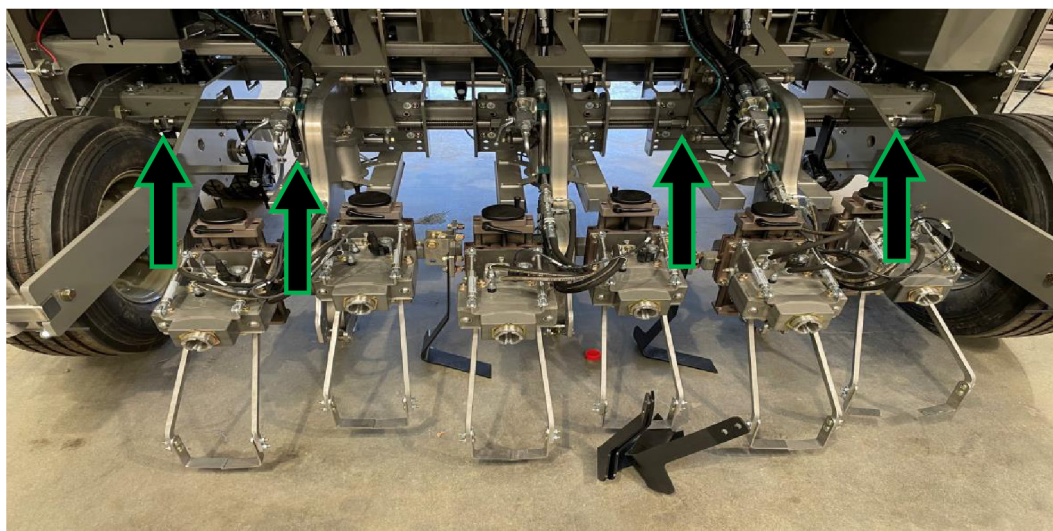
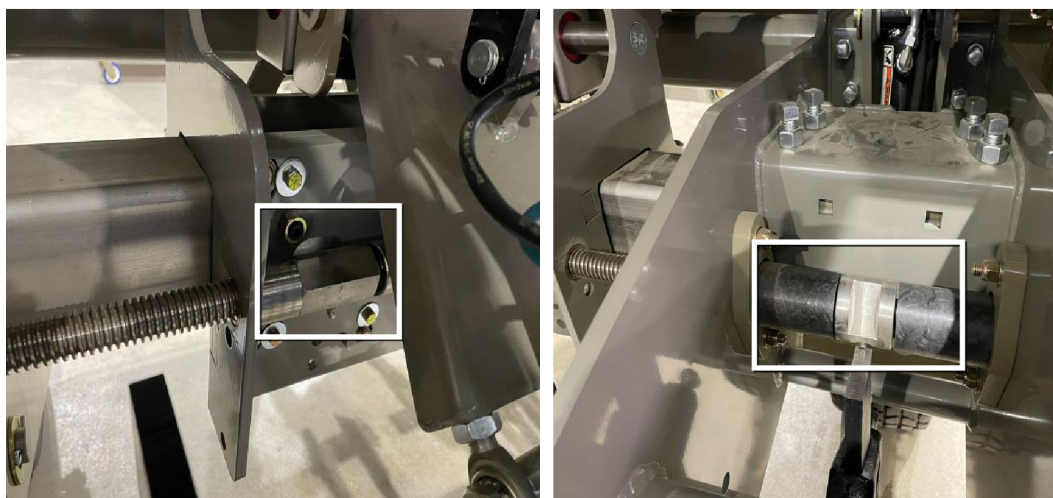
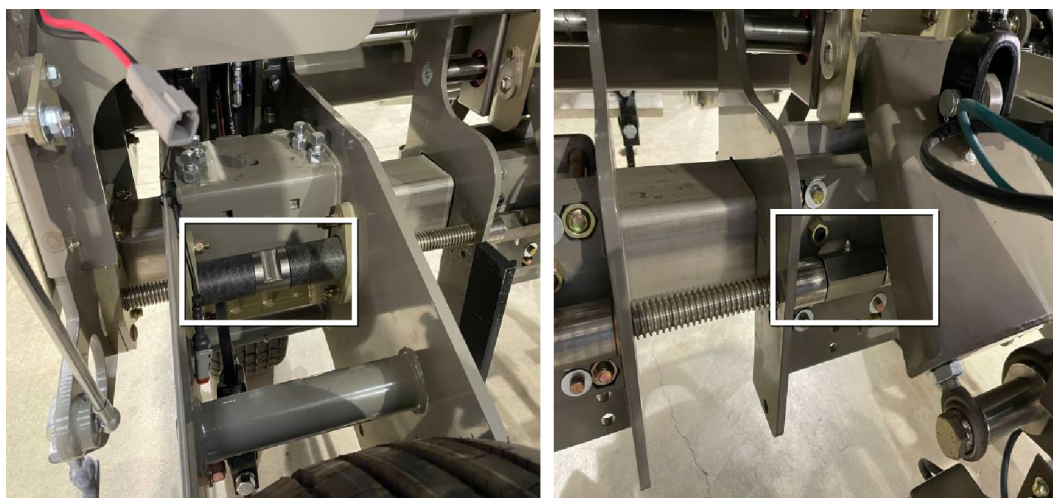

4. OPERATING INSTRUCTIONS

After completing the previous step, the following steps will require the movement of the backbones. This procedure references the measurements taken from the inside of the gauge wheel brackets, which are approximately 177.8 cm (70 in) apart. Begin by bringing in backbone 2, so actuator 4 sits at the corner of the 177.8 cm (70 in) - at the 88.9 cm (35 in) location. Actuator 4 will be the center reference when spacing the remaining actuators.

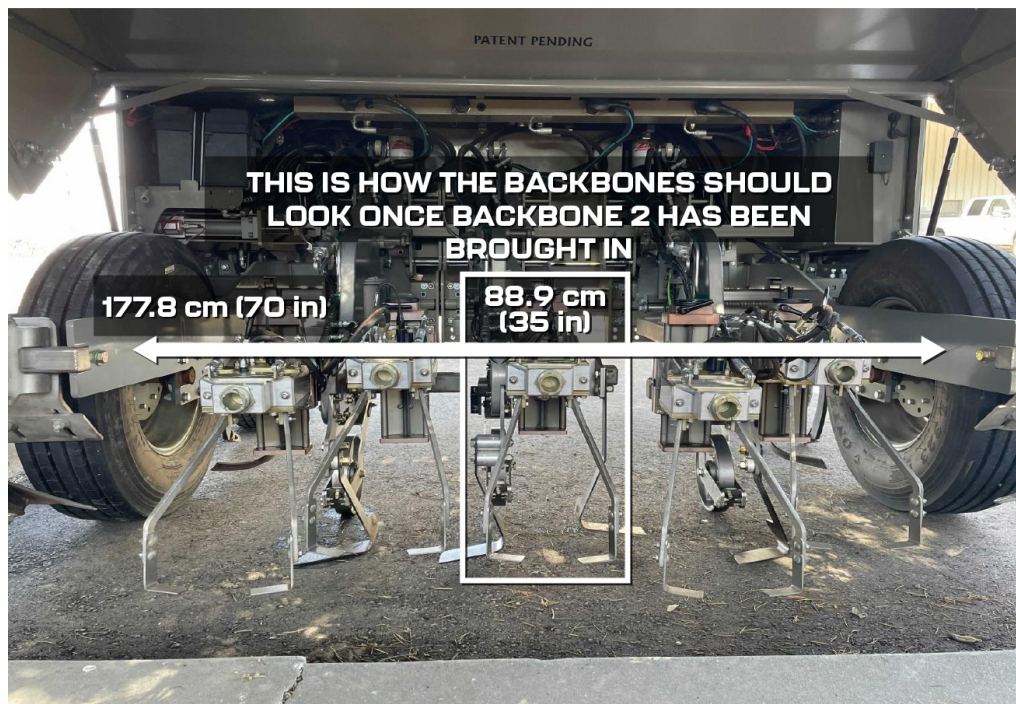
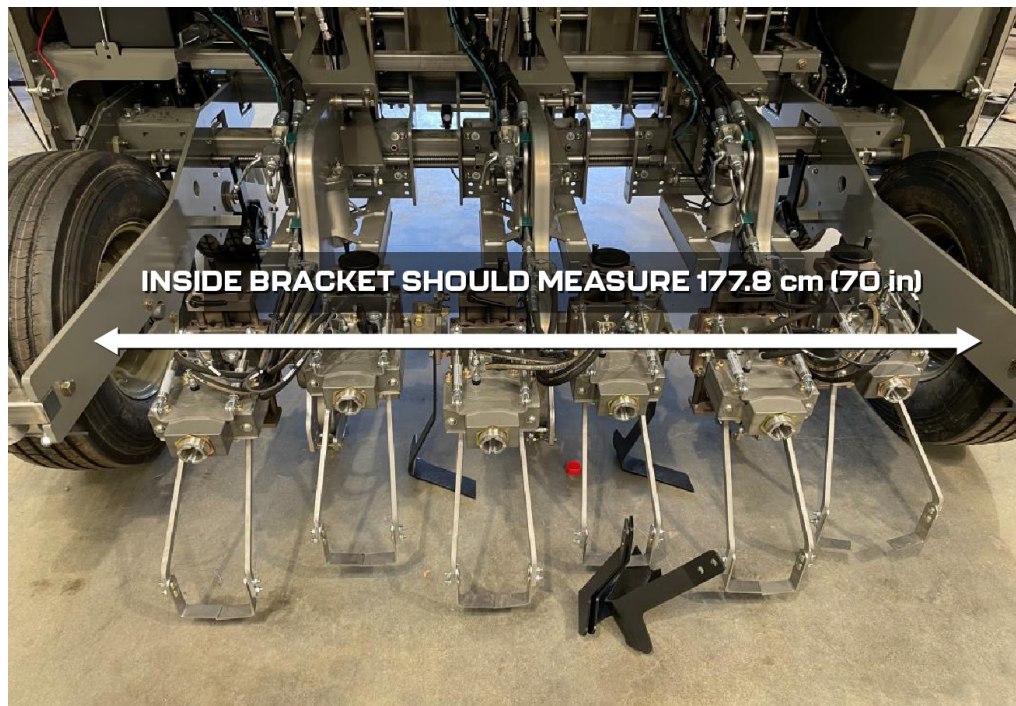

4. OPERATING INSTRUCTIONS

NOTE: It is recommended to have two people assist with the following steps.

STEP 4: Using a 1 3/8 in socket, turn the nut located on the outside of the machine. The nut will rotate the lead screw which is located on both the left and the right side; Only one side requires rotating, and either side can be chosen.

NOTE: Rotating the nut clockwise will draw the backbone closer to your position. Rotating the nut counterclockwise will push the wheel away from your position. Brackets on backbones 1 & 2 need to come together. Every 5 full turns are approximately 2.54 cm (1 in) of travel. As the nut is being rotated, place a crescent wrench on the lead screw on backbone 2 and ensure that it tightens (To confirm this is properly tightened, it is recommended a second person assist the this step). Rotate the nut, and ensure backbone 2 is moving closer to backbone 1. Stop once actuator 4 is centered at 88.9 cm (35 in). Following the same steps, place the crescent wrench on the lead screw under backbone 1 and move backbone 1 to the right until it contacts backbone 2.

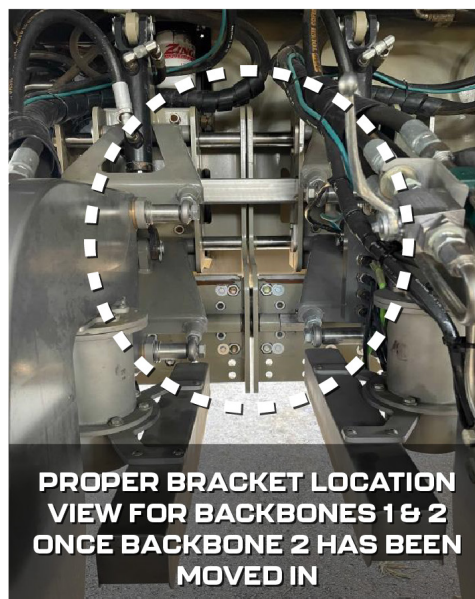
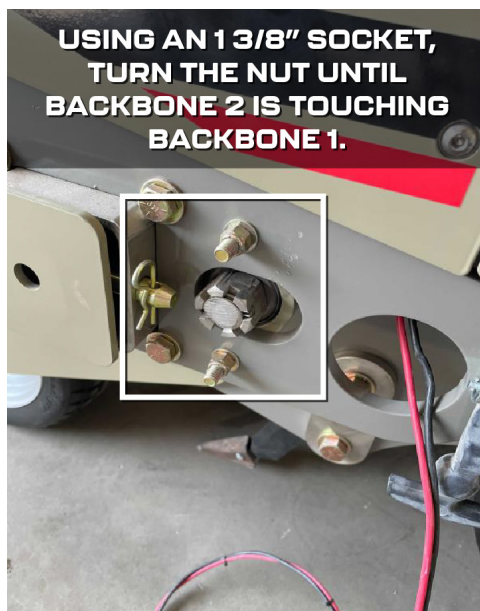

4. OPERATING INSTRUCTIONS

NOTE: It is recommended to have two people assist with the following steps.

STEP 5: Center actuators 5 & 6 on backbone 3 referencing the line spacing of the field. Once this is completed, move backbone 3 to the left (follow the same steps in the instructions on the previous page). Once the desired line spacing between actuators 4, 5 & 6 have been achieved, this step is complete.

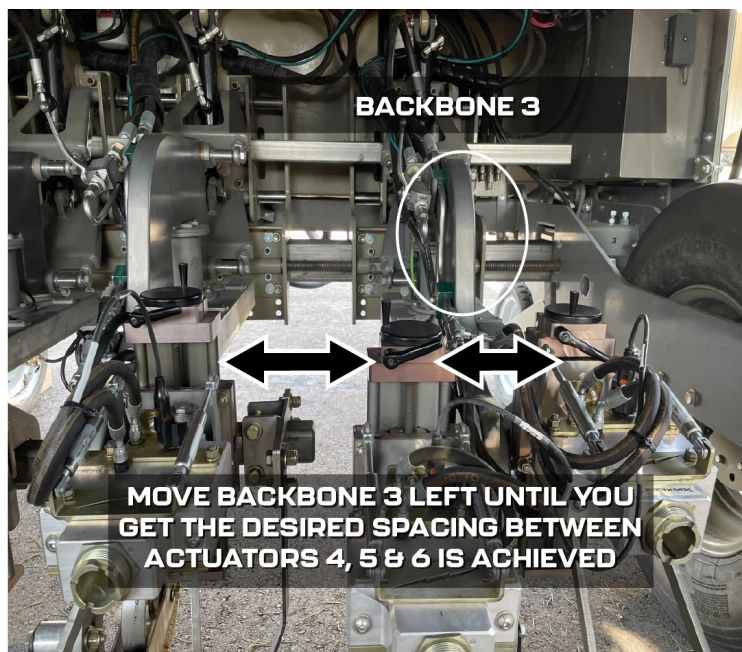
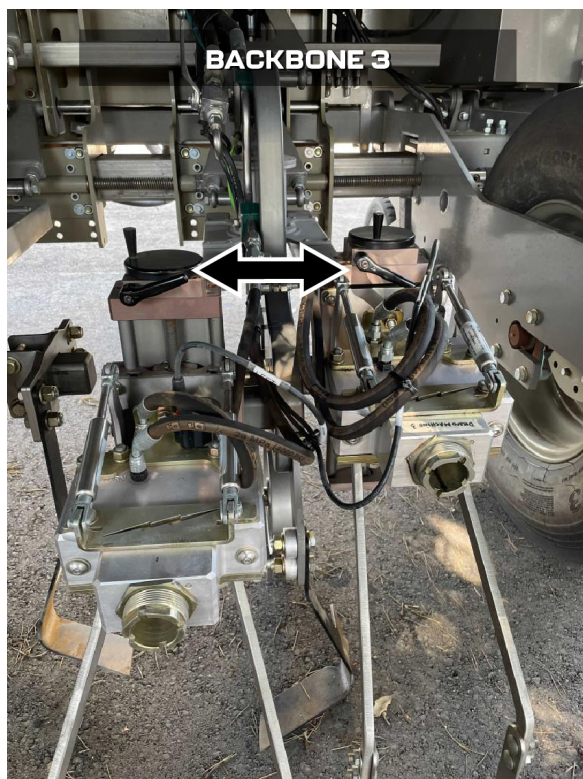

4. OPERATING INSTRUCTIONS

NOTE: It is recommended to have two people assist with the following steps.

STEP 6: Center the backbones within the brackets. Using a “2x4” (a thick & long piece of wood; approximately 5.08 cm (2 in) thick and 10.16 cm (4 in) wide) and the white blocks, place the white blocks where the shaft is and use the “2x4” as leverage to shift the backbone until it touches the white block. Both of the white blocks should fit snugly on each side. This will ensure the backbone is centered.

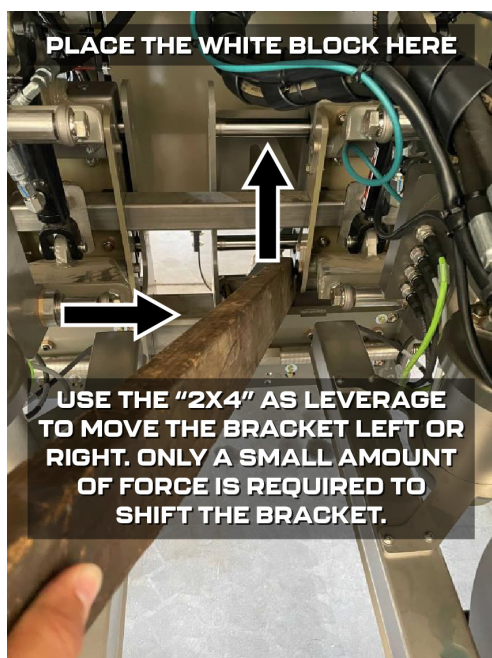

4. OPERATING INSTRUCTIONS

STEP 7: Adjust and align each actuator to the line spacing desired for the field. Actuator 4 will be used as the center reference point.

NOTE: It is important to understand that while the actuators may be spaced properly, based on the line-to-line spacing in the field, there may be some in-field adjustments required to accommodate the specific variables of each field.

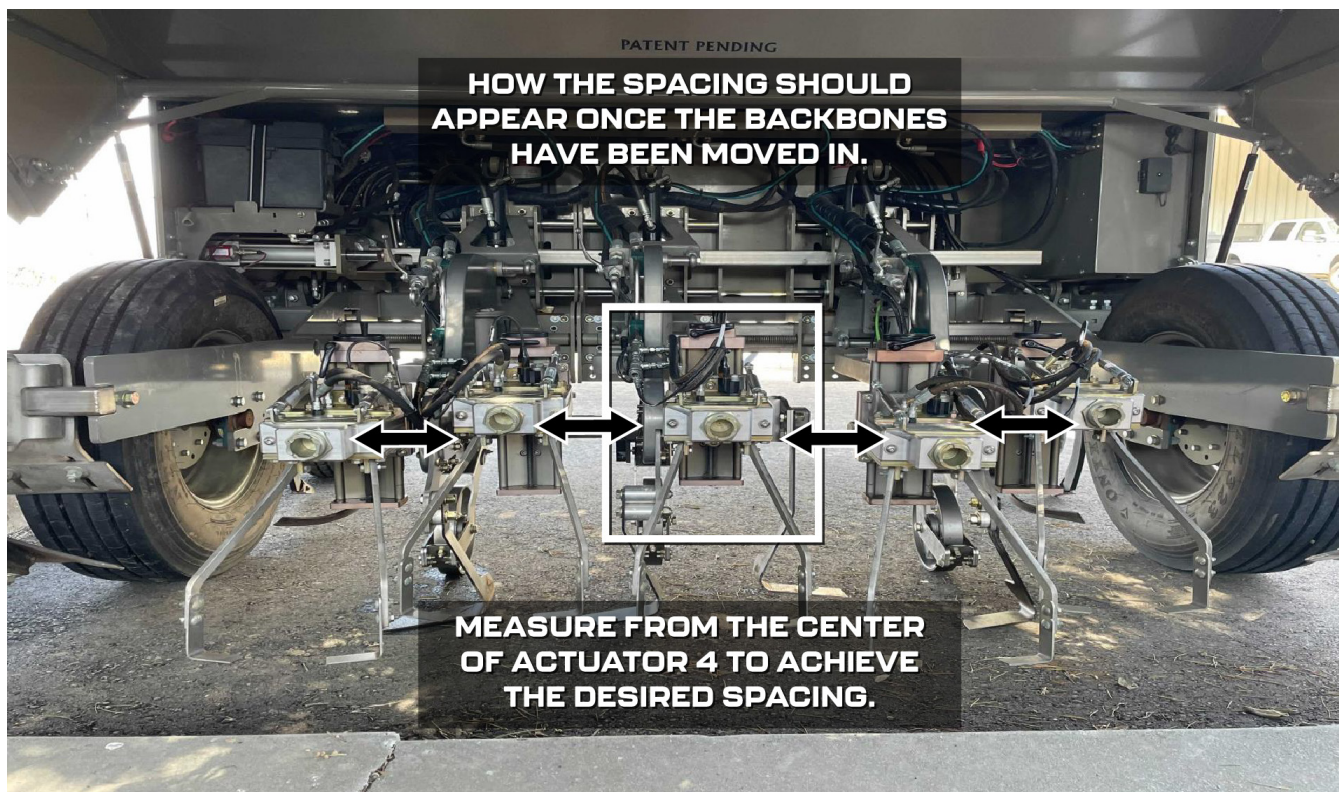

4. OPERATING INSTRUCTIONS

STEP 8: For the 5-line sweeps set up, add the provided spacers. A 1.59 cm (5/8 in) and 5.08 cm (2 in) spacer is required to provide proper spacing for the sweeps.

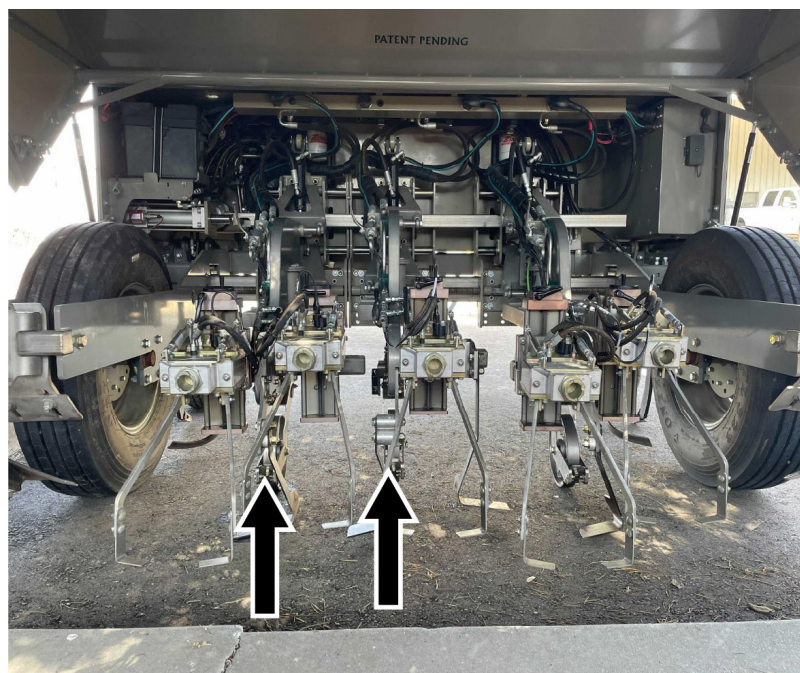

4. OPERATING INSTRUCTIONS

STEP 9: Once the backbones are centered, begin to tighten all the nuts that were loosened in the previous procedures. (Refer to the instructions on the previous pages.) Confirm everything is tightened, otherwise, the brackets may shift and cause spacing misalignment.

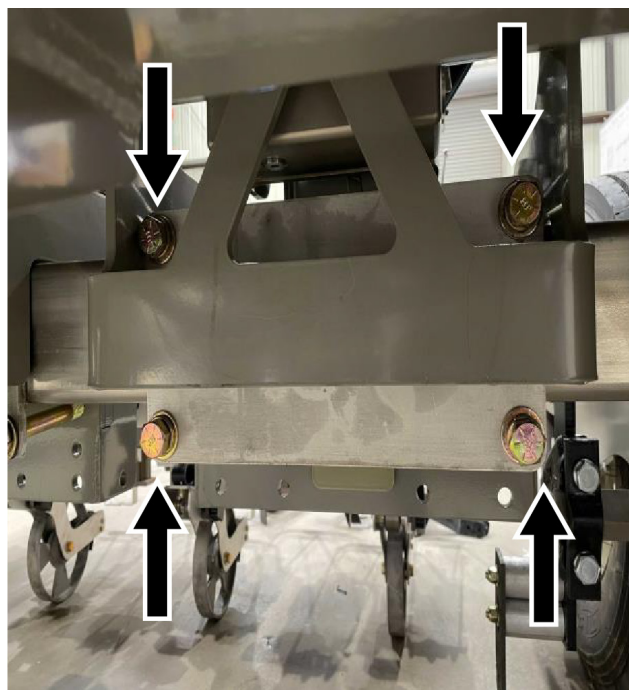

4. OPERATING INSTRUCTIONS

CONFIGURATION HOW TO: 6 LINE TO 4 LINE 40'S SET UP

WARNING! Do not have the tractor or the implement running while completing the following steps. Confirm that everything is off. Take all necessary measures to ensure that anyone working on the configuration of the implement can do so safely.

NOTE: 2 line 86.36 cm (34 in) spacing will require backbone 2 (center) to be removed. We recommend taking the machine to the Stout shop for that configuration.

Backbone 1 to backbone 3 should sit center in-between the 2 line crop rows. For example:

- 2 Line 96.52 cm (38 in) spacing - measure 48.26 cm (19 in) from the center of backbone 1 to backbone 3.
- 2 Line 101.6 cm (40 in) spacing - measure 50.8 cm (20 in) from the center of backbone 1 to backbone 3.
- 2 Line 106.68 cm (42 in) spacing - measure 53.34 cm (21 in) from the center of backbone 1 to backbone 3.

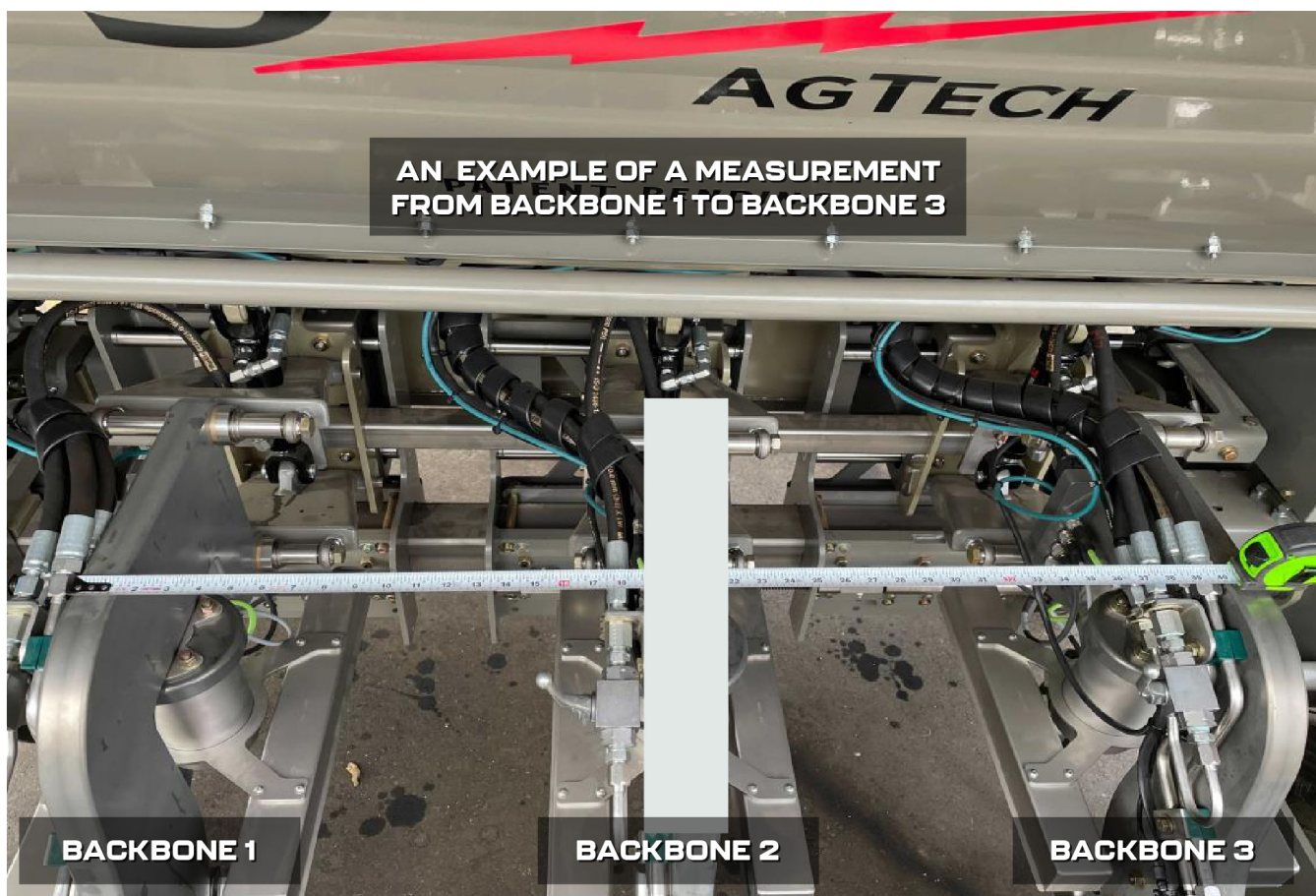

4. OPERATING INSTRUCTIONS

STEP 1: Pin-up and secure backbone 2 by locking the valve in the upright position. Backbone 2 should remain in the upright position while backbone 1 & 3 are lowered. Removing actuators should not be required. Complete this step by adjusting the actuators to achieve the desired spacing.

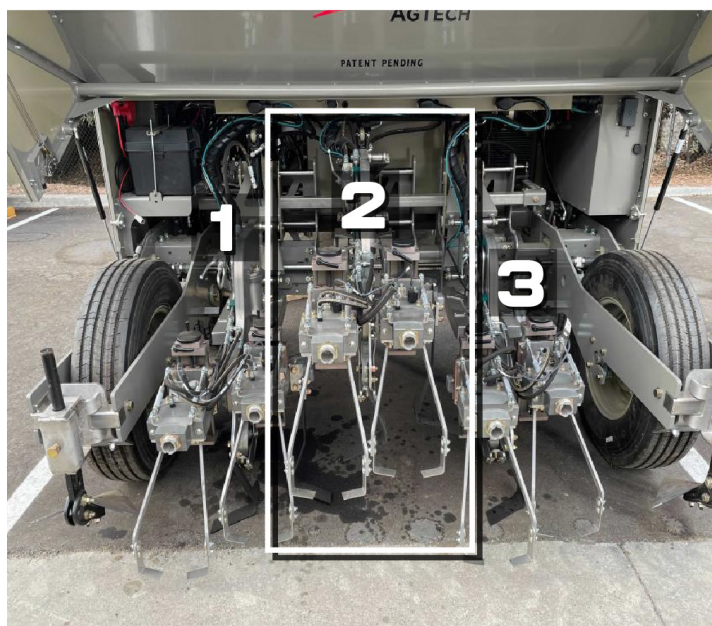
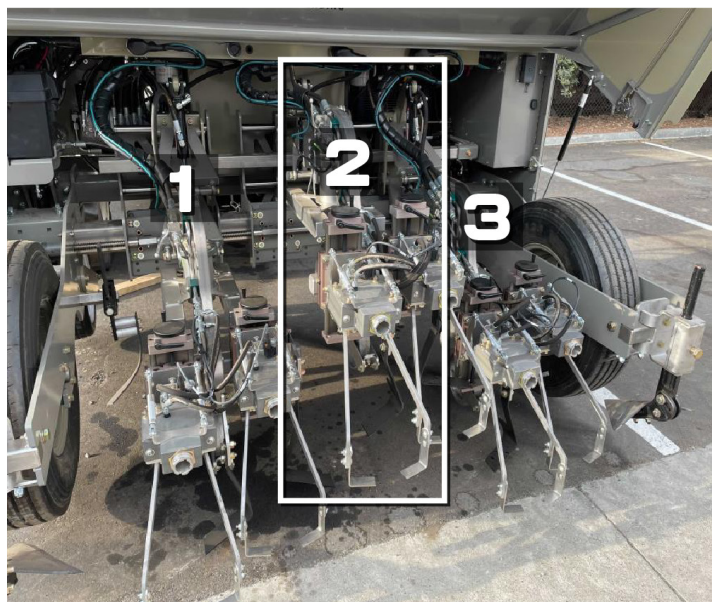

4. OPERATING INSTRUCTIONS

STEP 2: Select the “Setup” tab on the touchscreen.

- Tap “All” on “Modules Enabled”
- Select “Outer”

Selecting “Outer” will disable the actuators on backbone 2. This will prevent the blades from opening and closing while they are in an elevated position.

Note: Selecting “All” will enable all actuators to open and close. This is required when returning to a 5 or 6 line setup.



4. OPERATING INSTRUCTIONS

If further bracket adjustment is needed, proceed to the following bracket adjustment steps. The following steps are similar to the 5-line configuration steps.

Before starting this procedure, ensure the “Side Shift” is positioned at 0.0 - 0.3 on the touchscreen. If it is not positioned at 0.0 - 0.3, continuing this procedure may result in misalignment of all the backbones. In addition, it may require starting over and repeating the alignment procedures.

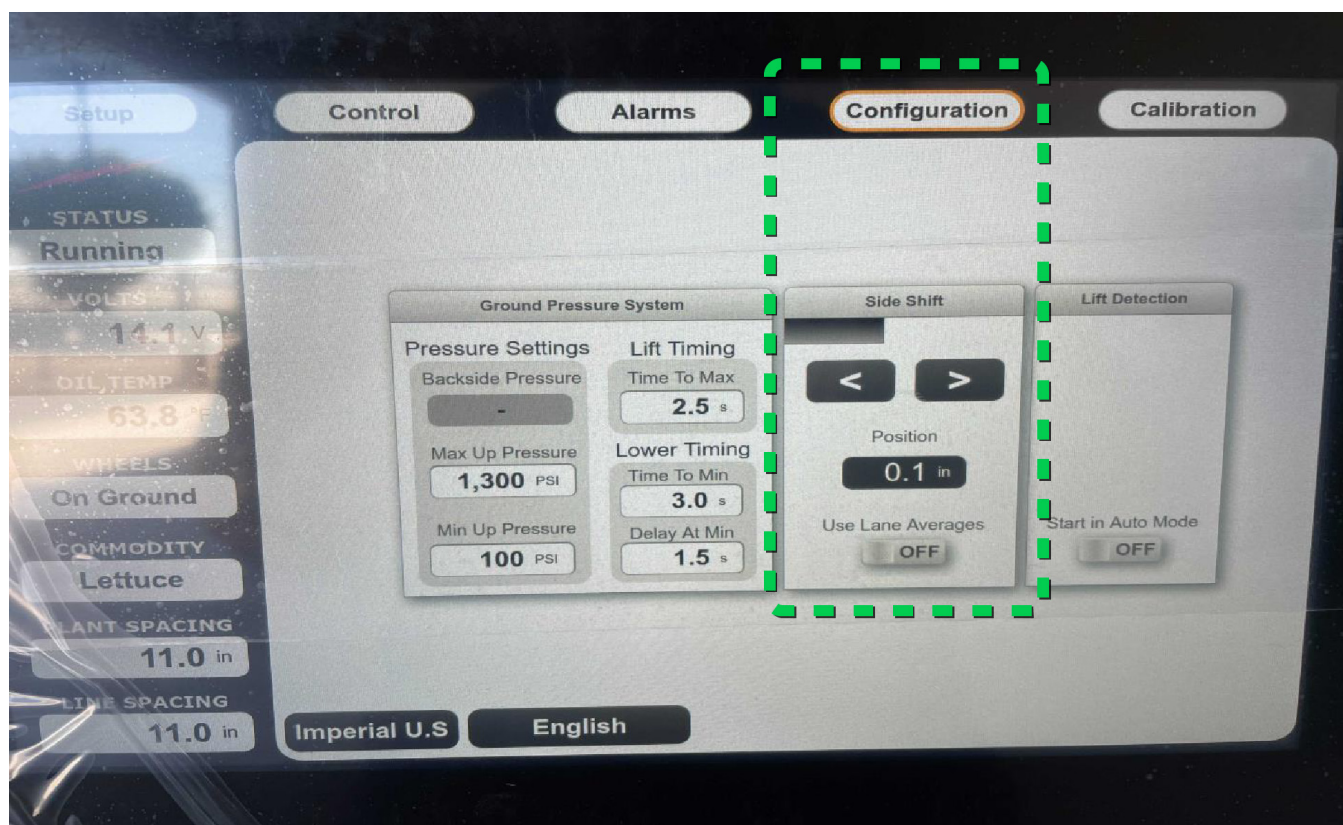

4. OPERATING INSTRUCTIONS

When the backbones require shifting to align with field measurements, complete the following steps:

1. Loosen lead screws located on the acme thread until they are rotating freely.
2. There are 5 screws - 2 located near the big gauge wheels and 1 under each backbone. It is recommended to use an adjustable crescent wrench for this step.

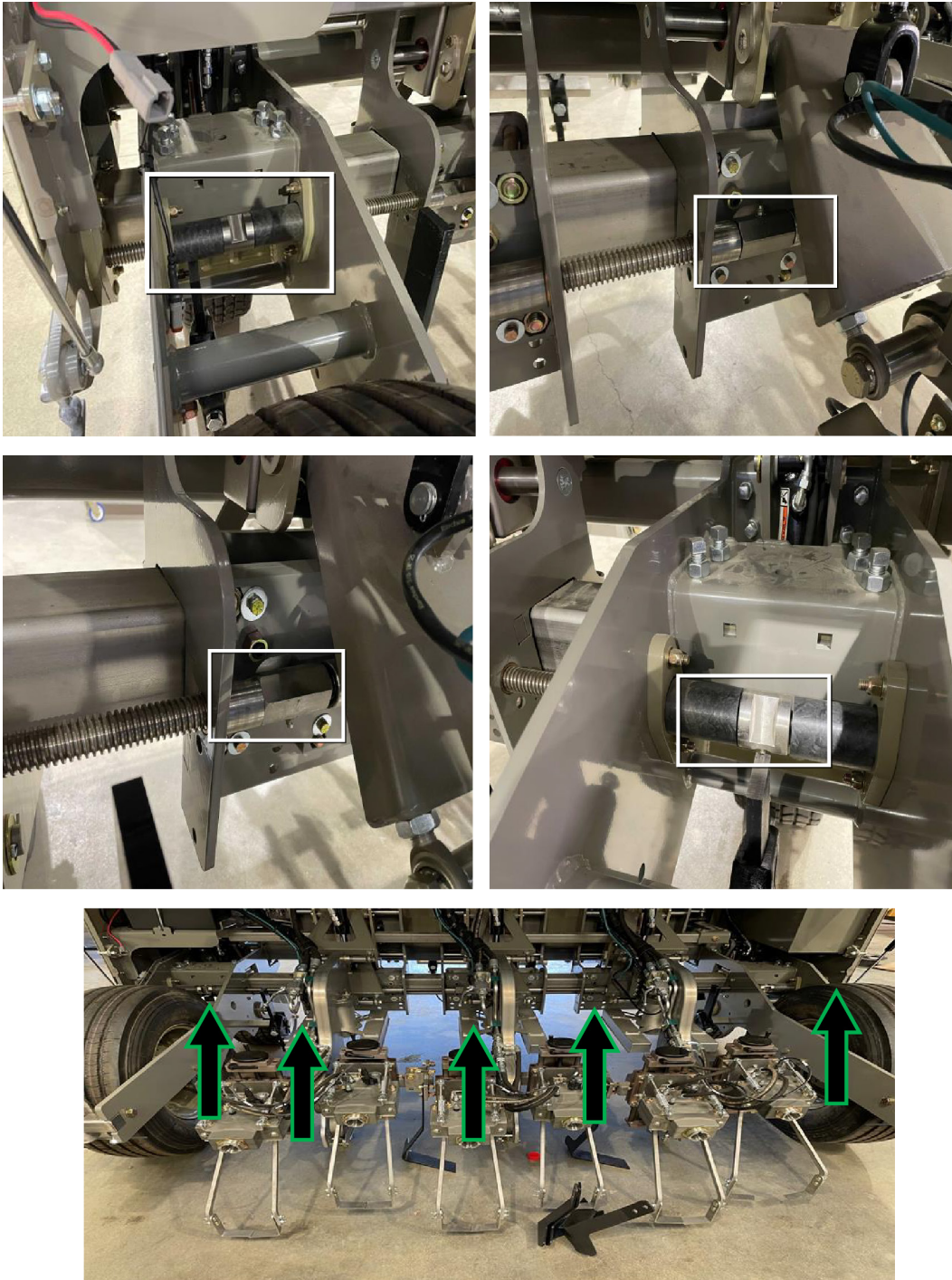

5. TRANSPORT OPERATIONS

TRANSPORT ON PUBLIC ROADS

WARNING

Transport hazard!

If the tractor hydraulic system accidentally engages during transport, the machine could drop to the ground, swing into roadside obstacles, or swing into oncoming traffic. Before transport, always engage the header lift lock valve and the tongue swing cylinder valve in the LOCKED position. Failure to comply could result in death or serious injury.

NOTICE: When you drive on sloping ground, you must be aware that the implement's high center of gravity will increase the risk of overturning, and also affects the road holding qualities around corners etc.

NOTE: The behavior of the tractor when you drive with the implement may vary. Adjust the style of driving to the conditions on the road. Pay special attention to the location of the center of gravity of these implement elements which are folded with the use of hydraulic cylinders. The maximum permissible speed for driving with the implement attached is 25 km/h (15.5 mph).

NOTE: Make sure that the implement is equipped with the correct lighting system and other traffic markings in accordance with the country's current rules. The implement must be equipped with front lights (position lights) and rear lights (turn signals, position lights, brake lights) connected to the electrical installation of the tractor. A triangle sign may be required to be mounted on a special grip for slow vehicles.

NOTE: In vertical transport position the wings must be folded in and the 3-point linkage must be lifted so that the transport height is below 4 meters and still safe clearance above the road from the lowest point. The exact transport height for the individual implements is stated under technical data (see Pg. 75).

NOTE: During transport and in operation, transporting people on the structure of the implement is strictly prohibited.

NOTE: Before you transport the implement on a public road, make sure not to exceed the transport height of **4m (13.1 ft)**.

Only transport the implement behind a tractor in the tractor linkage arms. Transport the implement only in the transport position.

Before you drive on public roads, convert the implement from transport to working position and back again to ensure that there is no air in the hydraulic system.

Always immobilize (close) the ball valve that secure the implement before you drive on public road.

Lift the sections and put into transport position to obtain the correct transport width and inhibit the sections from moving during transport.

Place the jacks into the transport position. Lift the jacks and secure the support in the transport position with a latch pin. Make sure that the four latch pins are reengaged-gaged.

When you drive with the implement attached on any public roads, railway tracks or other surfaces, never exceed the transport width specified by applicable regulations. If the maximum permissible transport width is exceeded, then, in extraordinary conditions, the authorities may issue a special permit for the transport of a large-size vehicle.

Always observe the principles for permissible axle loads, the total implement mass and the transport gauge.

When you turn or drive next to corners, maintain a safe distance to account for the inertia of the implement and location of the center of gravity of the folded frame, which is at height.

After you finish the transport, before you leave the tractor, always lower the implement to the ground to the parking position, turn off the tractor engine, remove the key from the ignition and pull the hand brake.

To lower the center of gravity, and to ensure more stable transport conditions, the implement must be lowered to the lowest position available, ensuring however that there is sufficient space from the surface of the road.

Make sure that the implement is safe and that nothing falls off it during transport, for instance large lumps of soil.

Control the operation of the implement's lights and the condition of warning plates.

5. TRANSPORT OPERATIONS

SHIPPING TRANSPORT LIFTING THE IMPLEMENT

WARNING

Falling object hazard!

DO NOT go underneath a hanging load. Make sure the area is clear of all bystanders. Failure to comply could result in death or serious injury.

WARNING

Crushing hazard!

Use the machine lifting points when you lift and/or move the machine with heavy handling equipment. Lift the machine only from the indicated lifting eye hookup points. Always use adequate lifting equipment. Failure to comply could result in death or serious injury.

If you lift the implement with a crane or a forklift, always proceed according to the following guidelines:

- The crane or forklift used to lift the implement must have proper lifting capacity and is equipped with proper ballast.
- Always use transport belts with proper load-bearing capacity.

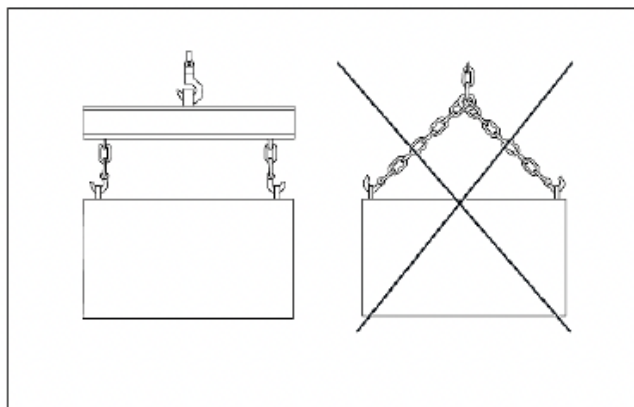

5. TRANSPORT OPERATIONS

LOADING AND UNLOADING OF THE IMPLEMENT WITH SUITABLE LIFTING DEVICE

For loading and unloading the implement, use only a suitable lifting device with an operational operating brake system.

- When you perform the loading / unloading procedure, ask an additional person for help in guiding the equipment.
- When you load the implement, close and secure hood with rubber latches (1) and secure machine using the tie down points (2) on both sides of machine.

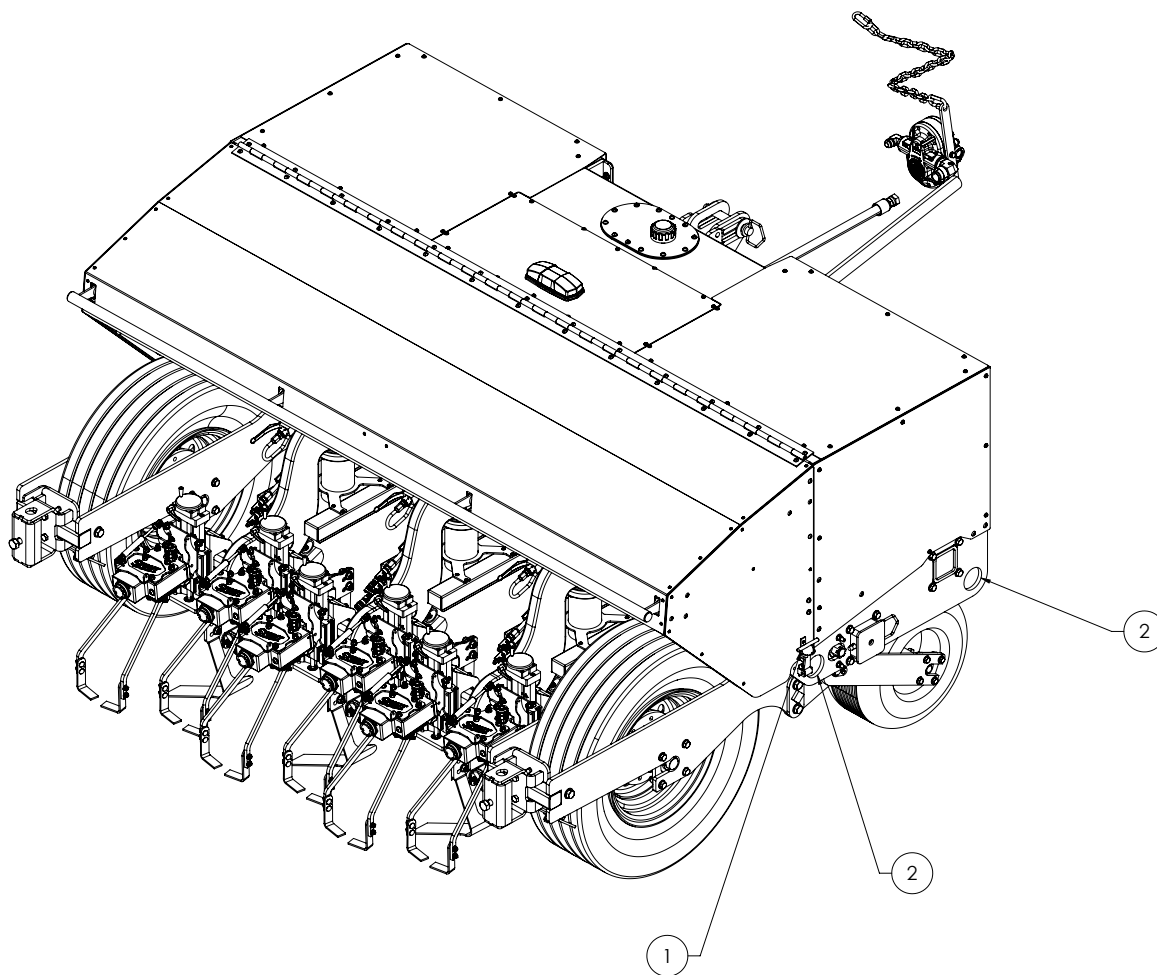

6. MAINTENANCE

TIRE PRESSURE SETTINGS

Maintain 4.14 Bar (60 PSI) at all times.

FLUIDS, LUBRICANTS AND CAPACITIES

Application	Capacity	Product Name
Threads and Cranks	As required	Silver Grade Anti-Seize
Grease Fittings	As required	Multi-Vehicle Red Grease
Actuator Assembly, Shafts Reservoir	As required	3-in-One Multi-Purpose Oil

RECOMMENDED TOOLS

Specification	Task
1/2 in Drive Ratchet	Bracket Adjustment
1/2 in Drive x 45.72 cm (18 in) Breaker Bar	Bracket Adjustment
1/2 in Drive x 6 in Extension	Bracket Adjustment
1/2 in Drive x 15/16 in Deep 12-Point Socket	Bracket Adjustment
1/2 in Drive x 1-3/8 in Deep 12-Point Socket	Bracket Adjustment
15/16 in Combination Wrench	Bracket Adjustment
12 in Crescent Wrench	Bracket Adjustment
3/8 in Drive Ratchet	Actuator Adjustment
3/8 in Drive x 3/4 in 12-Point Socket	Actuator Adjustment
3/4 in Combination Wrench	Actuator Adjustment
1/2 in Drive x 18" Extension	Wheel Adjustment
1/2" Drive Universal Joint	Wheel Adjustment
3/8" Drive x 18 in Extension	Wheel Adjustment
3/8 in Drive Universal Joint	Wheel Adjustment
Standard Hex Key Set	Panel Removal

6. MAINTENANCE

HIGH PRESSURE FILTER MAINTENANCE

Maintaining the incoming High Pressure Filter on the Smart Cultivator is pertinent when operating the machine. Before turning on the Smart Cultivator, verify that the indicator on the top is green (1). This ensures the filter is operating properly during the use of the machine.

If the indicator is showing red (2), press the top button (3) of the indicator down to turn the indicator back to green. This indicates that the High Pressure Filter is filtering properly. If the indicator does not turn back to green or if indicator is red during operation, it is time to service or replace the filter element.



(1)



(2)

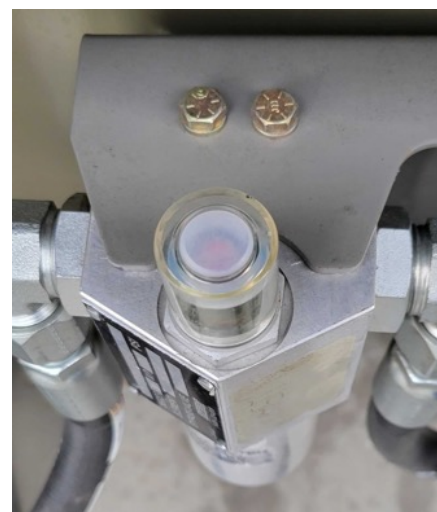

(3)

6. MAINTENANCE

HEIGHT CONTROL WHEEL MAINTENANCE

Ensure the height control is clean of any dirt or mud to operate properly. The wheel must be able to rotate during operation. Use wheel scraper to remove any debris from the wheel during operation. To adjust, break nut (1) loose and slide scraper (2) with about 3.81 cm (1/8 in) in gap between scraper and wheel.

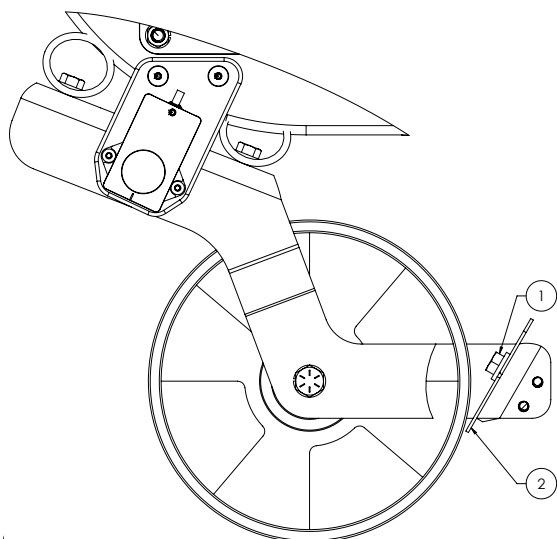
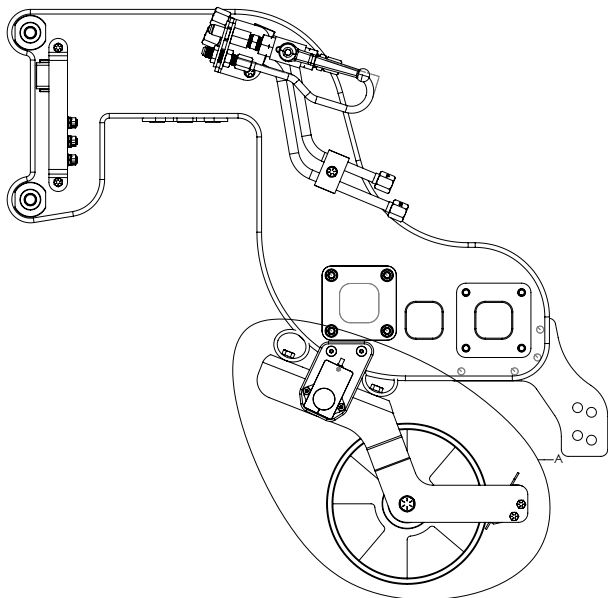

6. MAINTENANCE

PRESSURE SETTINGS

NOTE: Implement pressure settings are properly set before leaving Stout. If the pressures need to be checked and/or adjusted, follow this procedure or call for assistance.

These instructions explain how to set the following hydraulic system settings:

- Alternator speed
- Side shift pressure
- Cultivator arm pressure
- Module lift system back pressure

IMPORTANT: When attaching or removing the test gauge, the PTO must be turned off. The PTO must be turned back ON while reading and adjusting the pressure.

DANGER: Parts of the machine may move unexpectedly. Keep clear of all moving parts while turning the PTO on, off and when adjusting pressures.

DANGER: The alternator belt and associated pulleys may begin spinning unexpectedly during these procedures. Stay clear of the belt pulleys at all times.

TOOLS NEEDED:

- 137.90 Bar (2000 PSI) pressure gauge with quick disconnect fitting
- 9/16 in Open-end wrench
- 5/32 in Hex key / allen wrench
- 3/16 in Hex key / allen wrench
- 1/4 in Hex key / allen wrench
- 3/4 in Open end wrench
- Contact tachometer such as Protmex PT6208A

The pressure manifold is located on the front left side of the machine (when viewing the machine from behind).

STEP 1: Remove pressure manifold cover panel (8 screws) using 5/32 in hex key.

STEP 2: Start the machine.

STEP 3: Turn on the main electrical switch to finish loading.

STEP 4: Open the Control tab.



6. MAINTENANCE

STEP 5: Set pump pressure (only necessary for a full system pressure reset).

Break nut loose by using 9/16 wrench and insert 3/16 hex key into PFC1 adjustment stem. Turn the stem all the way in going clockwise.



Break nut loose by using 9/16 wrench and insert 3/16 hex key on PR's 2-8 (Cultivator arm, back pressure, side shift) - turn stem counterclockwise all the way



Attach gauge to the TPP Pump.

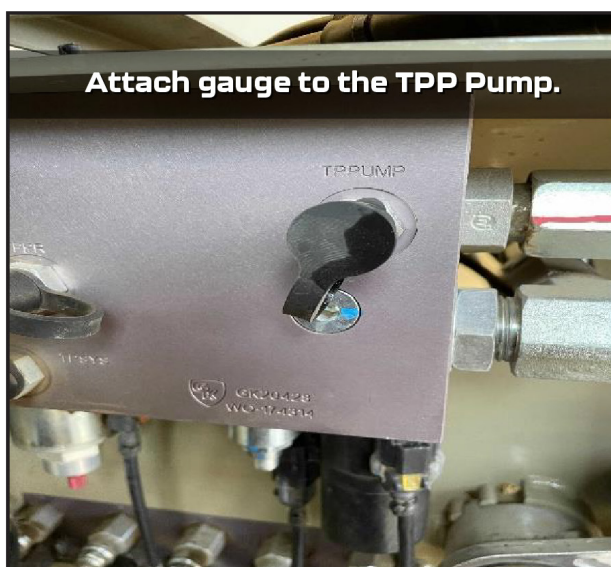

6. MAINTENANCE

Break the jam nut loose with a 3/4 in wrench and insert a 1/4 in hex key on the RV1 Pump Relief - Turn on PTO pump. Next turn the hex key clockwise. At the same time, press and hold the minus symbol on the touchscreen machine angle option. Continue holding the minus symbol until the pressure gauge reads 103.42 Bar (500 PSI). Once the pressure gauge displays the correct Bar (PSI), turn on PTO pump and lock the jam nut on the RV1 Pump Relief.

NOTE: It is recommended to have two people assist for this procedure. This step is primarily performed when completing the initial machine setup.



6. MAINTENANCE

STEP 6: Setting the alternator flow rate.

NOTE: Ensure the oil temperature is at least 38°C (100°F) before starting this procedure.

THE ALTERNATOR FLOW RATE IS ADJUSTED USING PFC1. BREAK NUT LOOSE BY USING A 9/16 WRENCH, INSERT THE 3/16 HEX KEY INTO PFC1 ADJUSTMENT STEM.

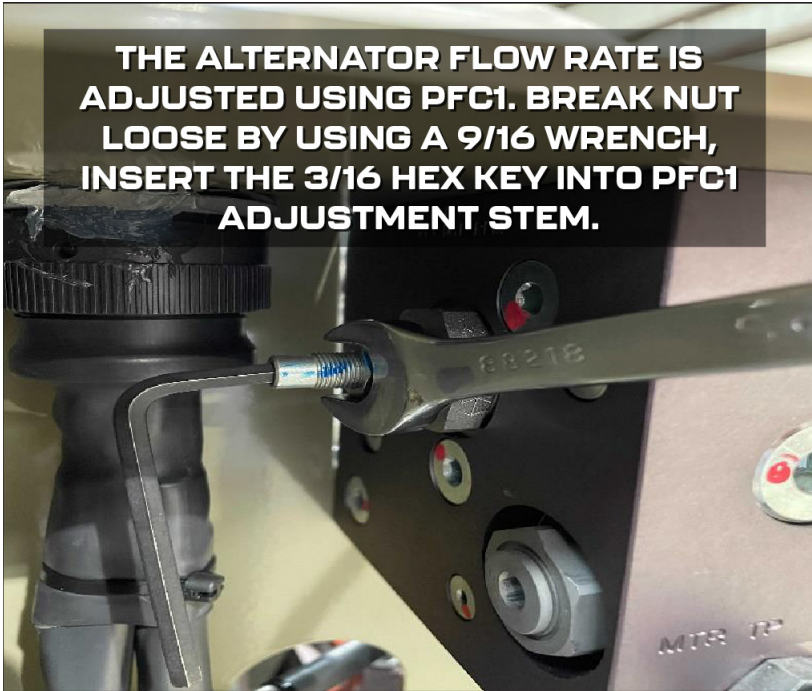

ENSURE THE ALTERNATOR IS ROTATING AT 2000 RPM'S. A TACHOMETER IS REQUIRED FOR THIS STEP. NOTE: THE IMAGE DOES NOT SHOW CORRECT RPM'S.



6. MAINTENANCE

Once this is completed, the “Volts” displayed on the control screen should read no less than 13.8v.

NOTE: If the operating voltage is less than 13.8v, the machine will not function properly.

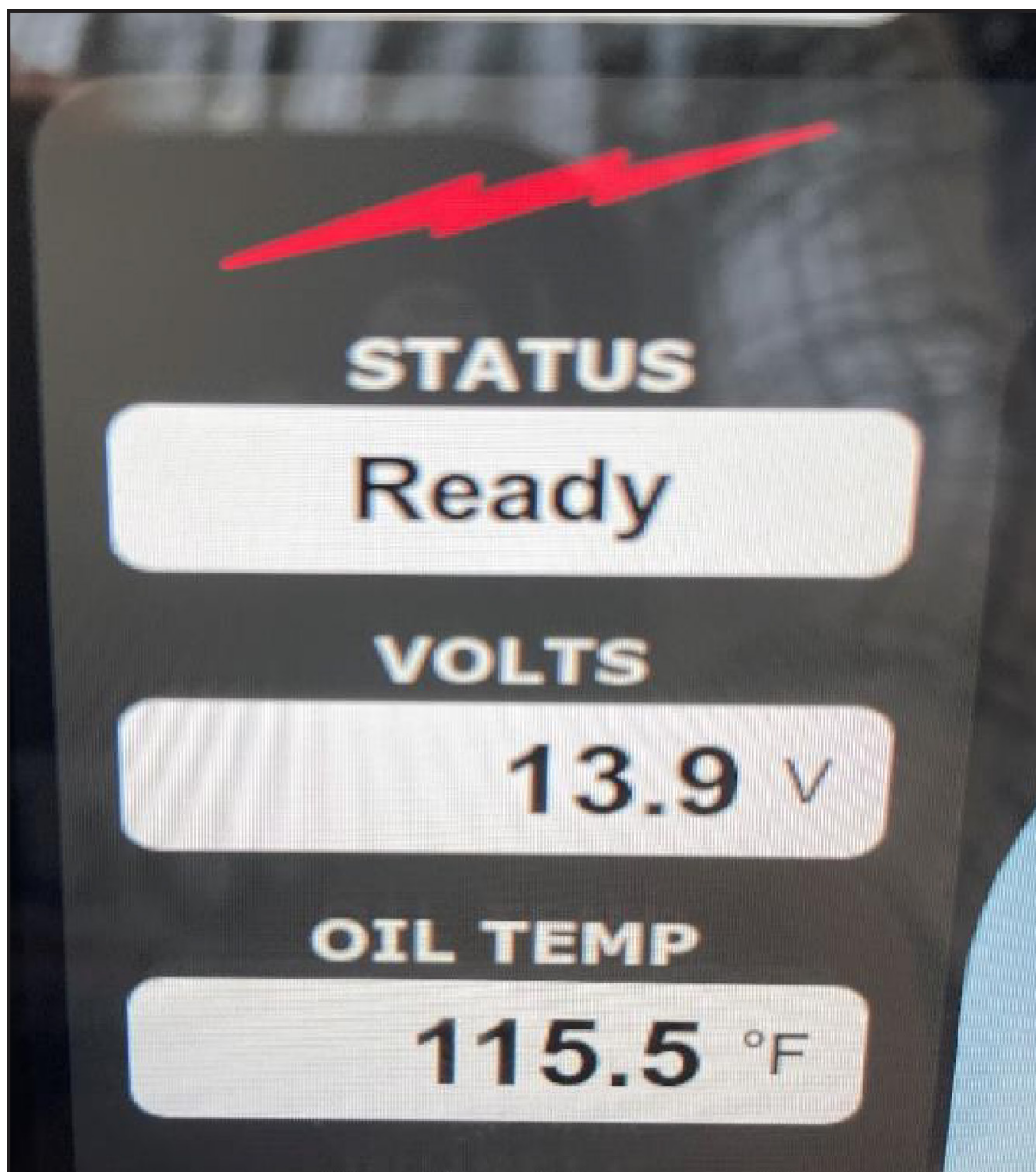

6. MAINTENANCE

STEP 7: Implement Arm Pressure.



6. MAINTENANCE

STEP 8: Side Shift.

TURN OFF PTO. ATTACH TEST GAUGE TO GAS. TURN ON PTO. BREAK NUT ON PR8 LOOSE BY USING A 9/16 WRENCH AND INSERT THE 5/32 HEX KEY INTO THE ADJUSTMENT STEM. TURN LEFT OR RIGHT TO SET 51.71 Bar (750 PSI). TIGHTEN NUT ONCE COMPLETED.

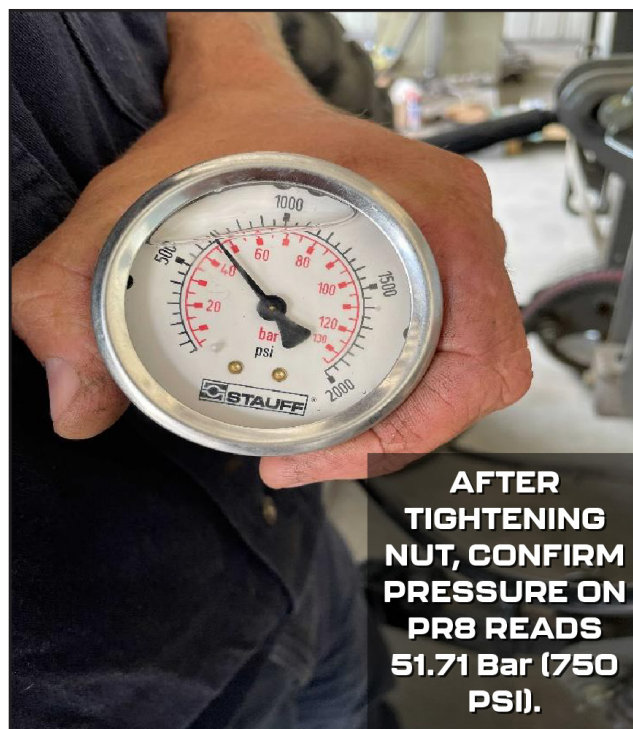
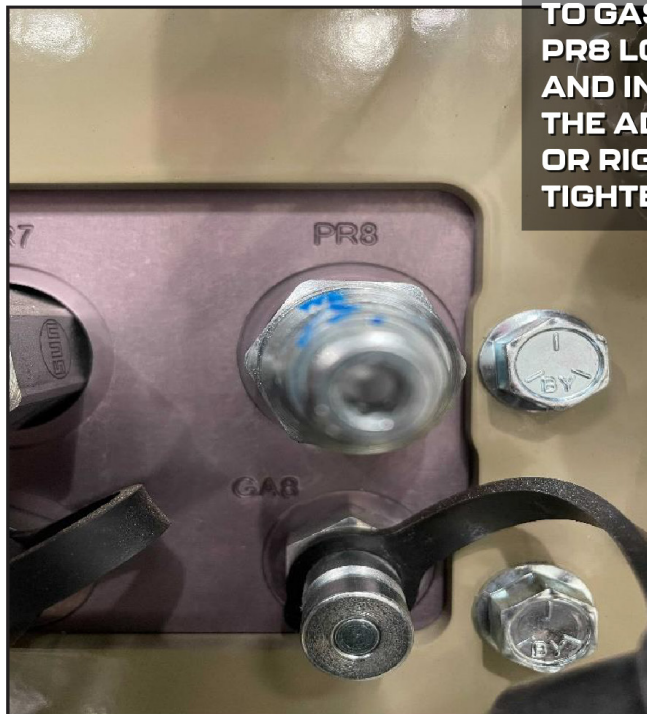

AFTER TIGHTENING NUT, CONFIRM PRESSURE ON PR8 READS 51.71 Bar (750 PSI).

6. MAINTENANCE

STEP 9: Module Back Pressure.

TURN OFF PTO. ATTACH TEST GAUGE TO GA4-GA7 (FOLLOWING THESE STEPS ONCE FOR EACH PORT). TURN ON PTO. BREAK NUT ON PR4-PR7 LOOSE BY USING A 9/16 WRENCH AND INSERT THE 5/32 HEX KEY INTO THE ADJUSTMENT STEM. TURN LEFT OR RIGHT TO SET 10.34 Bar (150 PSI). TIGHTEN NUT ONCE COMPLETED.



AFTER TIGHTENING NUT, CONFIRM PRESSURE ON PR4-PR7 IS 150 PSI.

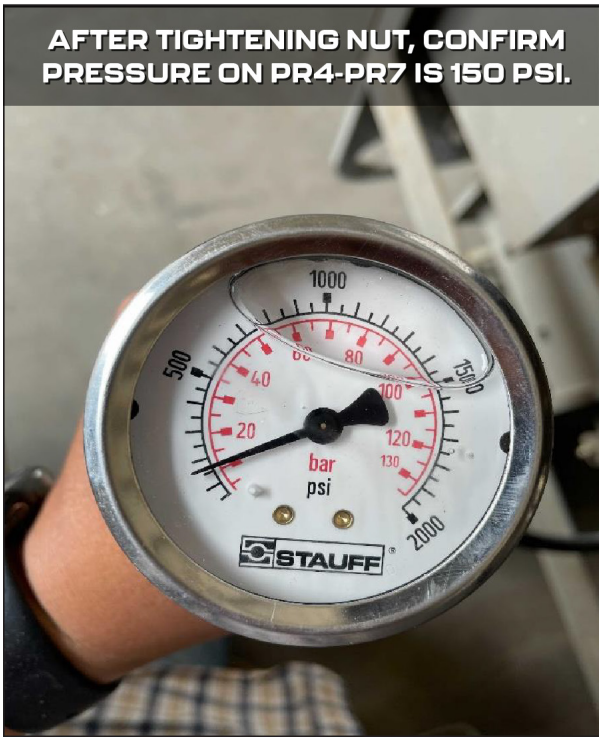

REPEAT THE PREVIOUS STEPS FOR GA5-GA7 AND PR5-PR7.

6. MAINTENANCE

STEP 10: Replace the pressure manifold cover panel and associated screws.



7. TROUBLESHOOTING

NOTE BEFORE TROUBLESHOOTING:

- 540 RPM shaft on the tractor is a 6 spline
- 1000 RPM shaft on the tractor is 21 spline
- Operator needs to read tractor manual to know how to select & engage correct option between 540 RPM or 1000 RPM (cannot select 540 RPM option on the tractor with a 1000 RPM shaft physically installed, and vice versa).
- Whether 540 RPM or 1000 RPM – once PTO is engaged, tractor RPM need to be set at 2000 RPM. RPM cannot fluctuate during operation, they need to remain at 2000 RPM while implement is on.

TROUBLESHOOTING I PROBLEM:

The hydraulic system is not operating.

CHECK: Confirm the PTO is operating at 1000 RPM.

If not, ensure the PTO speed selector is set to 1000 RPM and increase the engine RPM as required.

CHECK: Confirm the Smart Cultivator touchscreen displays a voltage of at least 13.8v.

If not, the battery may have started in a discharged state. In this state, the implement charging system dedicates all available hydraulic power to charge the battery. The result is the remaining systems will not activate or function.

REMEDIATION PROCEDURE:

1. Ensure the module's lift valve levers are in the locked position (up).

NOTE: It does not matter which position the modules are in

2. Deactivate the PTO
3. Turn off the main switch on the implement
4. Reactivate the PTO
5. Wait 1 minute
6. Turn the main switch of the implement on and follow the start-up procedures as outlined on page 37

8. SPECIFICATIONS



TECHNICAL DATA

Name	Configurations of SC180					Configurations of SC440	
	SC180X2	SC180X4	SC180X5	SC180X6	SC180X8	SC440X8	SC440X12
Frame Width	2.62 m (8.6 ft)					4.19 m (13.75 ft)	
Frame Length	2.25 m (7.38 ft)					2.13 m (7 ft)	
Frame Height	1.36 m (4.48 ft)					1.36 m (4.48 ft)	
Machine Weight	1487.78 kg (3,280 lb)	1542.21 kg (3,400 lb)	1696.44 kg (3,740 lb)	1723.65 kg (3,800 lb)	1905.09 kg (4,200 lb)	2109.20 kg (4,650 lb)	2190.85 kg (4,830 lb)
Number of Modules	2	2	3	3	4	4	4
Number of Plant Rows	2	4	5	6	8	8	12
3-Point Linkage	Class III					Class III	
PTO Pump Flow Rate	43.91 L/min - 51.10 L/min (11.6 - 13.5 gal/min)					43.91 L/min - 51.10 L/min (11.6 - 13.5 gal/min)	
Operating Hydraulic Oil Pressure	1500 psi					1500 psi	
Maximum Hydraulic Oil Pressure	3000 psi					3000 psi	
Electrical System	12V/24V					12V/24V	
Diameter of Large Gauge Wheels	76.2 cm (30 in)					76.2 cm (30 in)	
Diameter of Small Gauge Wheels	45.7 cm (18 in)					45.7 cm (18 in)	
Working Speed	Up to 4.67 km/hr (2.9 mph)					Up to 4.67 km/hr (2.9 mph)	
Transport Speed	Check the maximum speed of the combination tractor-implement in functional of the tractor approval, implement size and dimensions and local road circulation rules						

8. SPECIFICATIONS

WHEELS

There are two different type of support wheels on the frame:

- Wheel size: ST235/80R16 as Large Gauge Wheel (1)
- Wheel size: 18x8.5-12 as Small Gauge Wheel (2)

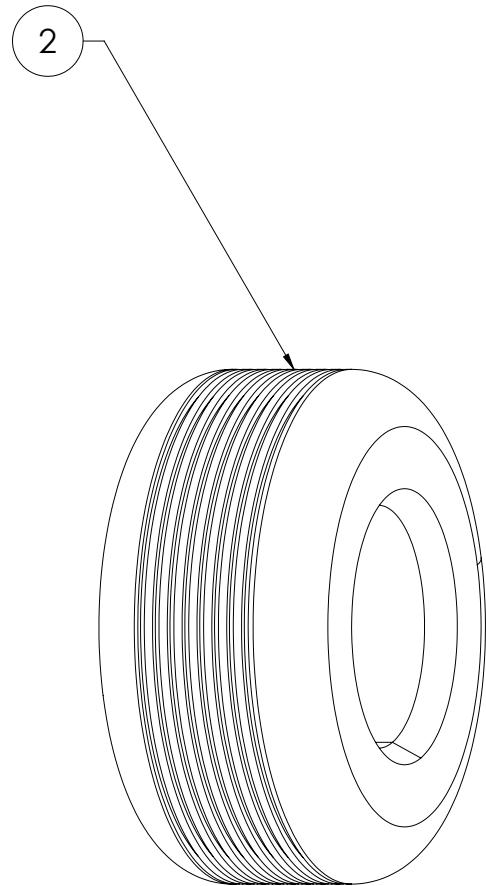
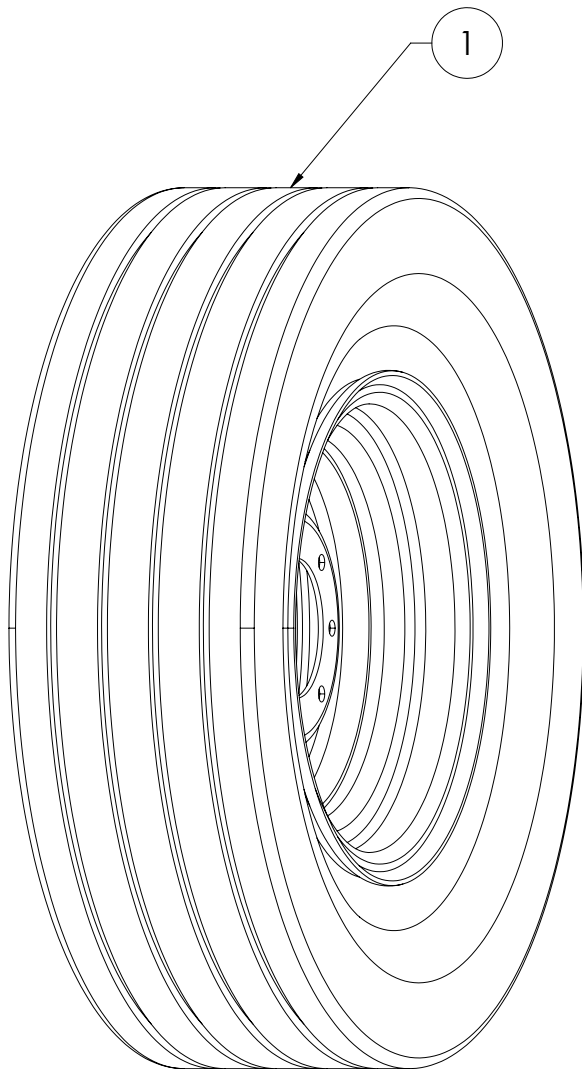

9. FORMS AND DECLARATIONS

For your better and easier understanding of the document, you will find the text reproduced hereafter.

EC / EU Declaration of Conformity
According to Directives 2006/42/EC & 2014/30 EU

We,

declare under our sole responsibility, that the product:

Agricultural machine

Commercial Name STOUT and Model:...

Denomination: Tillage

Type (Specify any variant/version:...

Planning key:...

Serial Number:...

to which this declaration relates, fulfills all the relevant provisions of Directives 2006/42/EC & 2014/30/EU, amended by: -

For the relevant implementation of the provisions of the Directives, the following (harmonized) standards have been applied:

- EN ISO 4254-1: 2015

Name, position, and address of the authorized person to compile the Technical Construction File:...

Place and date of the declaration:

Signature, name and position of person empowered to draw up the EC Declaration of Conformity:

9. FORMS AND DECLARATIONS



NOTE: Only for the United Kingdom.

	Declaration of Conformity of the Machinery according to Supply of Machinery (Safety) Regulations 2008 n.1597 and Electromagnetic Compatibility Regulations 2016 n.1091	[1]
1.A.1	We, [1] declare under our sole responsibility, that the product:	[2] [3] [4] [5]
1.A.3	Agricultural machine Commercial Name and Model: [2] Denomination: [3] Type (Specify any variant/version): [4] Planning key: [5] Serial Number: [6]	[6] [7] [8] [9]
1.A.4	to which this declaration relates, fulfills all the relevant provisions of these Regulations.	[10] [11] [12] [13]
1.A.7	For the relevant implementation of the provisions of these Regulations, the following published (designated) standards have been applied: [8]	[14] [15] [16] [17] [18]
1.A.2	Name: [9] Position: [10] and address: [11] of the person authorized to compile the Technical File:	[19] [20] [21] [22] [23]
1.A.9	Place: [12] and date: [13] of the declaration.	[24] [25] [26] [27]
1.A.10	Signature: [14] Name: [15] and position: [16] of the person empowered to draw up the UKCA Declaration of Conformity.	[28] [29] [30] [31] [32]

90498853 rev. A

The manufacturer and its authorized representative reserves the right to make improvements in design and changes in specifications at any time without notice and without incurring any obligation to install them on units previously sold. Specifications, descriptions, and illustrative material herein are as accurate as known at the time of publication, but are subject to change without notice.

Availability of some models and equipment builds varies according to the country in which the equipment is being used. For exact information about any particular product, please consult your dealer.

