

STOUT



THE SMART CULTIVATOR

TRACTOR COMPATIBILITY





THE SMART CULTIVATOR • TRACTOR COMPATIBILITY

TABLE OF CONTENTS

PAGE 03
LINK PINS
& PTO PUMP

PAGE 04
SMALL TOOLBAR

PAGE 05
LARGE TOOLBAR

PAGE 06
COMPATIBLE TRACTORS



SMART CULTIVATORS COME EQUIPPED WITH LINK PINS AND PTO PUMP

THREE-POINT HITCH (3ph) TRACTOR REQUIREMENTS:

- Category 2, 3ph
 - Does not support quick hitch attachment
- PTO Powered
 - Tractor requires 540 RPM shaft or 1,000 RPM shaft
- Also available with Tractor Supplied Hydraulics

PTO PUMP

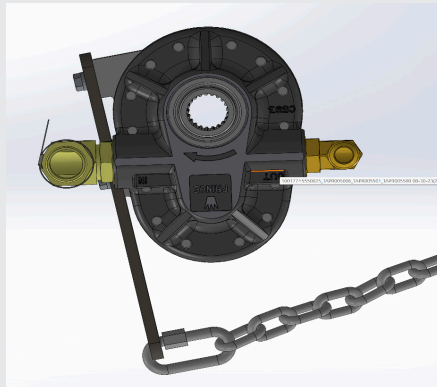

- 540 or 1,000 RPM PTO PUMP

SMALL TOOLBAR

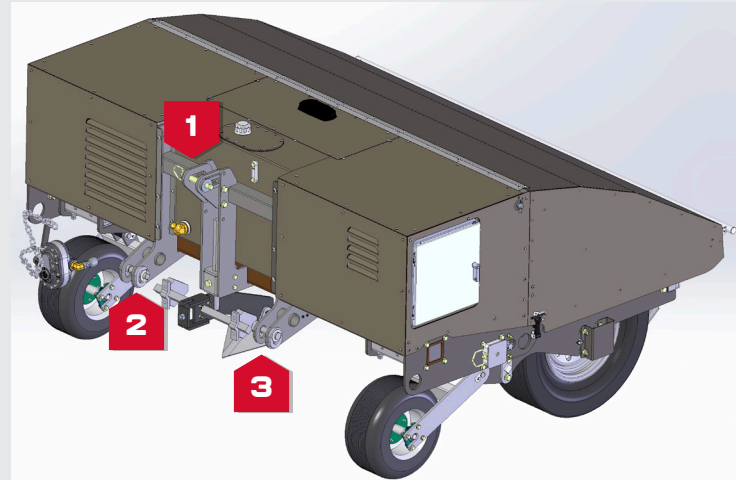

- [1] Top Link Pin Size: 1" diameter
- [2 & 3] Top Link Pin Size: 1 1/8" diameter

LARGE TOOLBAR

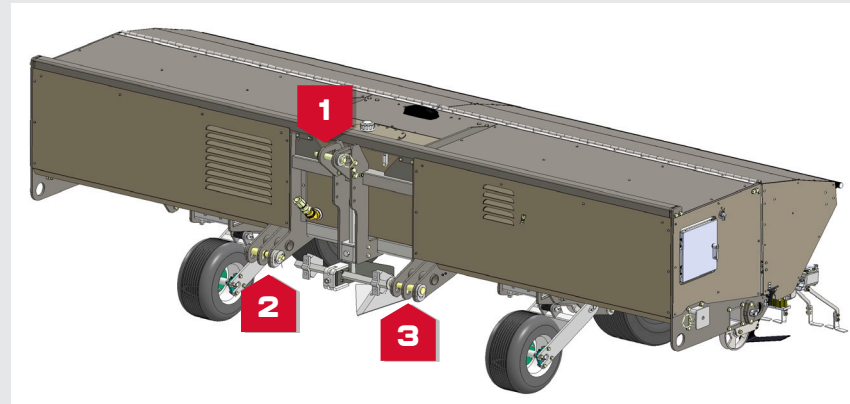

- [1] Top Link Pin Size: 1 1/2" diameter
- [2 & 3] Stepped Lower Pin Sizes:
 - 1 1/8" inner diameter
 - 1 7/16" outer diameter

SMALL TOOLBAR

WEIGHT: 2,600 TO 4,200 lbs • DEPENDING ON FINAL CONFIGURATION

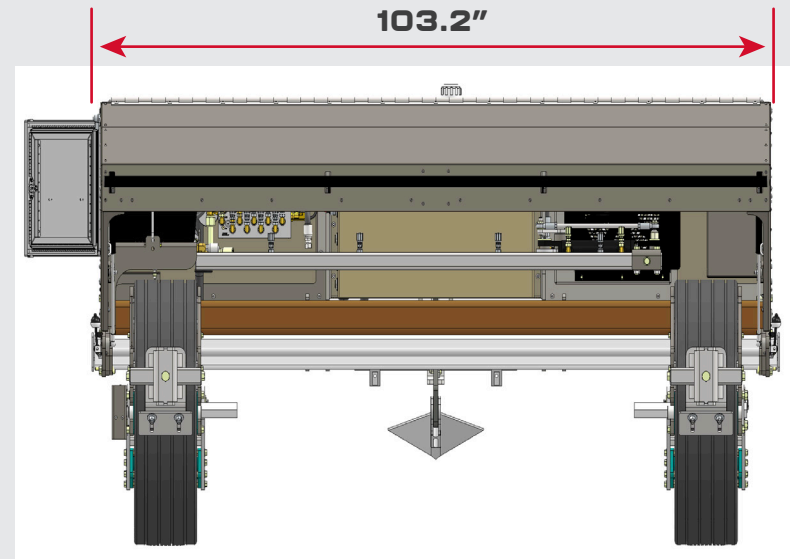
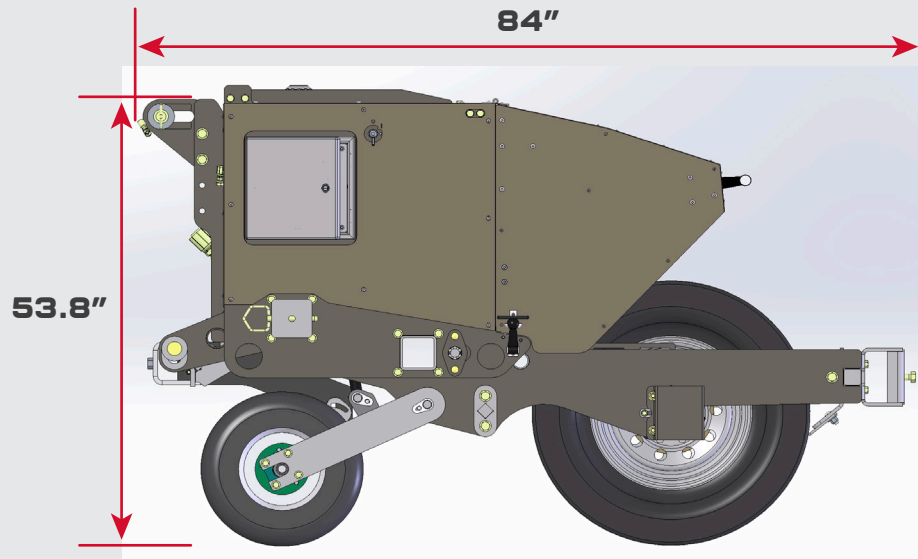

LARGE TOOLBAR

WEIGHT: 3,600 TO 7,000 lbs • DEPENDING ON FINAL CONFIGURATION

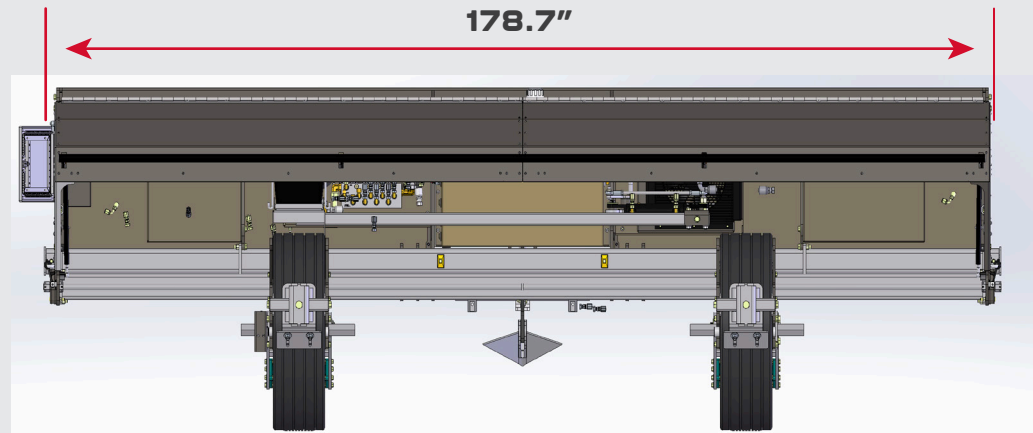
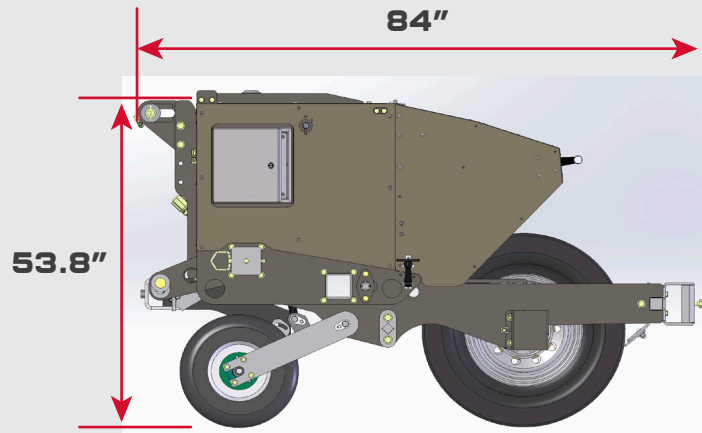

COMPATIBLE TRACTORS

JOHN DEERE

- 5 SERIES
- 6 SERIES

NEW HOLLAND

- T5 SERIES
- T6 SERIES

CASE

- FARMALL UTILITY LARGE 100A SERIES
- FARMALL UTILITY MEDIUM C SERIES
- FARMALL UTILITY MEDIUM M SERIES
- VESTRUM SERIES
- MAXXUM 115
- PUMA SERIES

KUBOTA

- 5 SERIES
- 6 SERIES

FENDT

- 300 VARIO SERIES
- 500 VARIO SERIES
- 700 VARIO SERIES

MASSEY FERGUSON

- MF 5700 SERIES
- MF 6700 SERIES

Tractor options are not limited to provided list. If your tractor is not listed, please ensure it meets the requirements of the Smart Cultivator's final configuration.